

M9102-AGA-2S, -3S and M9104-xGA-2S, -3S Series

Electric Non-Spring Return Actuators

Description

The M9102 and M9104 Series Actuators are direct-mount, non-spring return electric actuators that operate on AC 24 V power. These synchronous motor-driven actuators provide floating control (AGA), floating control with automatic shutoff (IGA), and proportional control with selectable 0-10 or 2-10 VDC (GGA). The -2S models are equipped with plenum cables, and the -3S models are equipped with terminal blocks.

All models are compact in size and are easily installed on Variable Air Volume (VAV) boxes, Variable Volume and Temperature (VVT) two-position zone applications, or small- to medium-sized dampers with a round shaft up to 1/2 in. (13 mm) in diameter or a 3/8 in. (10 mm) square shaft.

The M9102 Series Electric Non-Spring Return Actuators provide a running torque of 18 lb-in (2 N-m), and the nominal travel time is 30 seconds at 60 Hz (36 seconds at 50 Hz) for 90° of rotation. The M9104 Series Electric Non-Spring Return Actuators provide a running torque of 35 lb-in (4 N-m), and the nominal travel time is 60 seconds at 60 Hz (72 seconds at 50 Hz) for 90° of rotation.

Refer to the *M9102-AGA-2S, -3S and M9104-xGA-2S, -3S Series Electric Non-Spring Return Actuators Product Bulletin (LIT-1201742)* for important product application information.

Features

- two torques available: 18 and 35 lb-in (2 and 4 N-m) — offer the most suitable choice for the specific application
- short 30-second travel time available — provides a quick response for two-position zone applications
- 35 dBA nominal audible noise rating — meets the audible noise requirements for open ceiling environments
- synchronous drive — provides a constant rotation time that is independent of the load
- 100,000 cycle rating — provides years of trouble-free service
- direct shaft mounting with single-screw coupler — reduces installation time and provides three-point shaft gripping
- magnetic clutch — protects the actuator gear train and the damper from damage due to excessive torque during a stall condition
- manual gear release — simplifies actuator setup and adjustments in the field
- plenum cable or screw terminal electric connections — make wiring quick and easy

- floating, floating with timeout, and proportional 0(2)...10 VDC control inputs available — offer a full range of control input options
- small, compact design — allows installation in tight-fitting locations

Applications

The M9102 and M9104 Series Electric Non-Spring Return Actuators are designed to position balancing, control, round, and zone dampers in Heating, Ventilating, and Air Conditioning (HVAC) systems. These electric actuators are also designed to position blades in a VAV box, or they can be used in VVT two-position zone applications.

Each actuator mounts directly to the surface in any convenient orientation using a single No. 10 self-drilling sheet metal screw (included with the actuator). No additional linkages or couplers are required. Electrical connections on the actuator are clearly labeled to simplify installation.

Repair Information

If the M9102 or M9104 Series Electric Non-Spring Return Actuator fails to operate within its specifications, replace the unit. For a replacement electric actuator, contact the nearest Johnson Controls® representative.



M9102/M9104 Series Electric Non-Spring Return Actuator

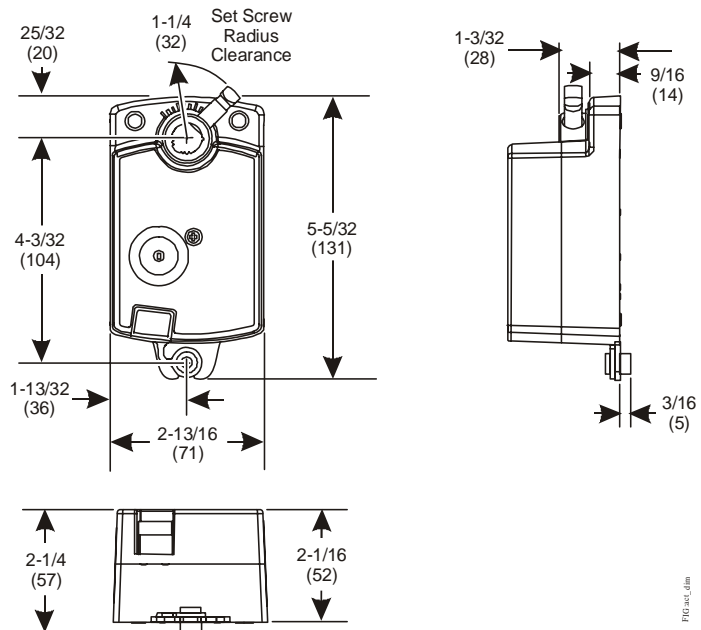

M9102/M9104 Series Electric Non-Spring Return Actuator Dimensions, in. (mm)

Electric Non-Spring Return Actuators (Continued)

Selection Chart

| Code Number | Control Type | Running Torque | Travel Time | Electrical Connections |
|--------------|--------------------|------------------|---------------------|--|
| M9102-AGA-2S | Floating | 18 lb-in (2 N-m) | 30 Seconds at 60 Hz | 48 in. (1.2 m) UL 444 Type CMP Plenum Rated cable with 19 AWG (0.75 mm ²) conductors and .25 in. (6 mm) ferrule ends |
| M9102-AGA-3S | Floating | 18 lb-in (2 N-m) | 30 Seconds at 60 Hz | M3 Screw Terminals |
| M9104-AGA-2S | Floating | 35 lb-in (4 N-m) | 60 Seconds at 60 Hz | 48 in. (1.2 m) UL 444 Type CMP Plenum Rated cable with 19 AWG (0.75 mm ²) conductors and .25 in. (6 mm) ferrule ends |
| M9104-AGA-3S | Floating | 35 lb-in (4 N-m) | 60 Seconds at 60 Hz | M3 Screw Terminals |
| M9104-IGA-2S | Floating or On/Off | 35 lb-in (4 N-m) | 60 Seconds at 60 Hz | 48 in. (1.2 m) UL 444 Type CMP Plenum Rated cable with 19 AWG (0.75 mm ²) conductors and .25 in. (6 mm) ferrule ends |
| M9104-IGA-3S | Floating or On/Off | 35 lb-in (4 N-m) | 60 Seconds at 60 Hz | M3 Screw Terminals |
| M9104-GGA-2S | Proportional | 35 lb-in (4 N-m) | 60 Seconds at 60 Hz | 48 in. (1.2 m) UL 444 Type CMP Plenum Rated cable with 19 AWG (0.75 mm ²) conductors and .25 in. (6 mm) ferrule ends |
| M9104-GGA-3S | Proportional | 35 lb-in (4 N-m) | 60 Seconds at 60 Hz | M3 Screw Terminals |

Accessories

| Code Number | Description |
|-------------|-------------|
|-------------|-------------|

Technical Specifications

| M9102-AGA-2S, -3S and M9104-xGA-2S, -3S Series Electric Non-Spring Return Actuators | | |
|---|--|--|
| Power Requirements | M910x-AGA-xS | AC 24 V +25%/-20% at 50/60 Hz, 2.1 VA Supply, Class 2, Safety Extra-Low Voltage (SELV) |
| | M9104-IGA-xS | AC 24 V +25%/-20% at 50/60 Hz, 3.0 VA Supply, Class 2, SELV |
| | M9104-GGA-xS | AC 24 V +25%/-20% at 50/60 Hz, 3.6 VA Supply, Class 2, SELV |
| Control Type | M910x-AGA-xS | Floating Control without Timeout |
| | M9104-IGA-xS | Floating or On/Off Control with Timeout |
| | M9104-GGA-xS | Proportional Control |
| Input Signal | M910x-AGA-xS | AC 24 V +25%/-20% at 50/60 Hz, Class 2, SELV without Timeout |
| | M9104-IGA-xS | AC 24 V +25%/-20% at 50/60 Hz, Class 2, SELV with Timeout |
| | M9104-GGA-xS | 0(2) to 10 VDC or 0(4) to 20 mA with field-furnished 500 ohm resistor |
| Feedback Signal | M9104-GGA-2S | 0 to 10 VDC or 2 to 10 VDC for 90° (10 VDC at 1 mA) Corresponds to input signal span selection |
| Motor Input Impedance | | 200 ohms Nominal |
| Running Torque | M9102 Series | 18 lb-in (2 N-m) |
| | M9104 Series | 35 lb-in (4 N-m) |
| Travel Time | M9102 Series | 30 Seconds at 60 Hz (36 Seconds at 50 Hz) for 90° of Rotation |
| | M9104 Series | 60 Seconds at 60 Hz (72 Seconds at 50 Hz) for 90° of Rotation |
| Rotation Range | | 93° ± 3°, CW or CCW |
| Cycles | | 100,000 Full Stroke Cycles; 2,500,000 Repositions at Rated Running Torque |
| Audible Noise Rating | | 35 dBA Nominal at 39-13/32 in. (1 m) |
| Electrical Connections | M9102-AGA-2S | 48 in. (1.2 m) UL 444 Type CMP Plenum Rated Cable with 19 AWG (0.75 mm ²) conductors and .25 in. (6 mm) ferrule ends |
| | M9104-xGA-2S | |
| | M9102-AGA-3S, M9104-xGA-3S | M3 Screw Terminals |
| Mechanical Connections | | Up to 1/2 in. (13 mm) Diameter Round Damper Shaft or 3/8 in. (10 mm) Square Damper Shaft |
| Enclosure | M9102-AGA-2S, M9104-xGA-2S | NEMA 2, IP42 |
| | M9102-AGA-3S, M9104-xGA-3S | NEMA 1, IP40 |
| Ambient Conditions | Operating | -4 to 140°F (-20 to 60°C); 90% RH Maximum, Noncondensing |
| | Storage | -20 to 150°F (-29 to 66°C); 90% RH Maximum, Noncondensing |
| Compliance | North America | UL Listed, File E27734, CCN XAPX (United States) and XAPX7 (Canada) |
| | | Actuator Housing is Plenum Rated per CSA C22.2 No. 236/UL 1995, Heating and Cooling Equipment |
| | European Union | CE Mark, EMC Directive 89/336/EEC |
| Australia and New Zealand | C-Tick Mark Australia/NZ Emissions Compliant | |
| Shipping Weight | | 1.0 lb (0.5 kg) |