

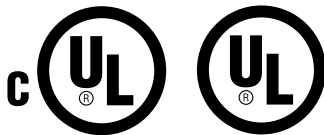

TECHNICAL GUIDE

SINGLE PIECE AIR HANDLERS FOR USE WITH SPLIT-SYSTEM COOLING & HEAT PUMPS MODELS: AHP18 THRU 60 AND SHP48 THRU 60



Due to continuous product improvement, specifications are subject to change without notice.

Visit us on the web at www.york.com

Additional rating information can be found at www.ahridirectory.org.

DESCRIPTION

This fan coil line offers the ultimate in application flexibility. The AHP (non-variable speed motor) models can be ordered upflow only or as multi-position. The multi-position model can be installed in downflow, upflow, horizontal right or left without the need for additional field installed kits.

The SHP 48 & 60 models are upflow only models designed into a shorter cabinet than the AHP version, for those special applications where reduced height is required.

All UPG air handlers and coils utilize a TXV to provide our customers with the optimum performance and refrigerant control required for 13+ systems. Air handlers can be ordered with a R22 or R410A TXV factory installed. Air handlers are also available with "Flex-coils" without a factory installed metering device. For added flexibility, an R22 or R410A TXV can be field installed to meet your refrigerant choice.

FEATURES

Thermal Expansion Valve - Provides the ultimate refrigerant control required for today's high efficient product. The UPG bolt-on TXV provides the added flexibility to convert the air handler to the required refrigerant. The UPG TXV is a true bolt-on which does not require brazing to replace or install.

MicroBlue™ Coated Fins - All air handler coils are treated with the MicroBlue™ hydrophilic coating to enhance the removal of condensate during the refrigeration cycle and reduce the possibility of water blow-off. The MicroBlue™ coating also reduces the growth of germ causing microbes for a healthier home environment.

Insulated Cabinet - All air handler cabinets are thermally insulated with 1" foil faced insulation (R-4.2) to prevent sweating. For applications in extreme humidity conditions an optional, field installed, external insulating wrap kit is also available.

Factory - Sealed to achieve 2% or less leakage rate with or without field installed filter at 1.0" water gauge external static pressure.

Durable Finish Inside and Out - Air handler casings are made of pre-painted galvanized steel which provides a better paint to steel bond that resists corrosion and rust creep. All internal coil sheet metal parts are made of G90 galvanized.

High Efficiency - 5 ton unit has high efficiency DC motor.

4 HK Heat Kit - Installation friendly, easy service, more robust, unique to new design.

DIMENSIONS

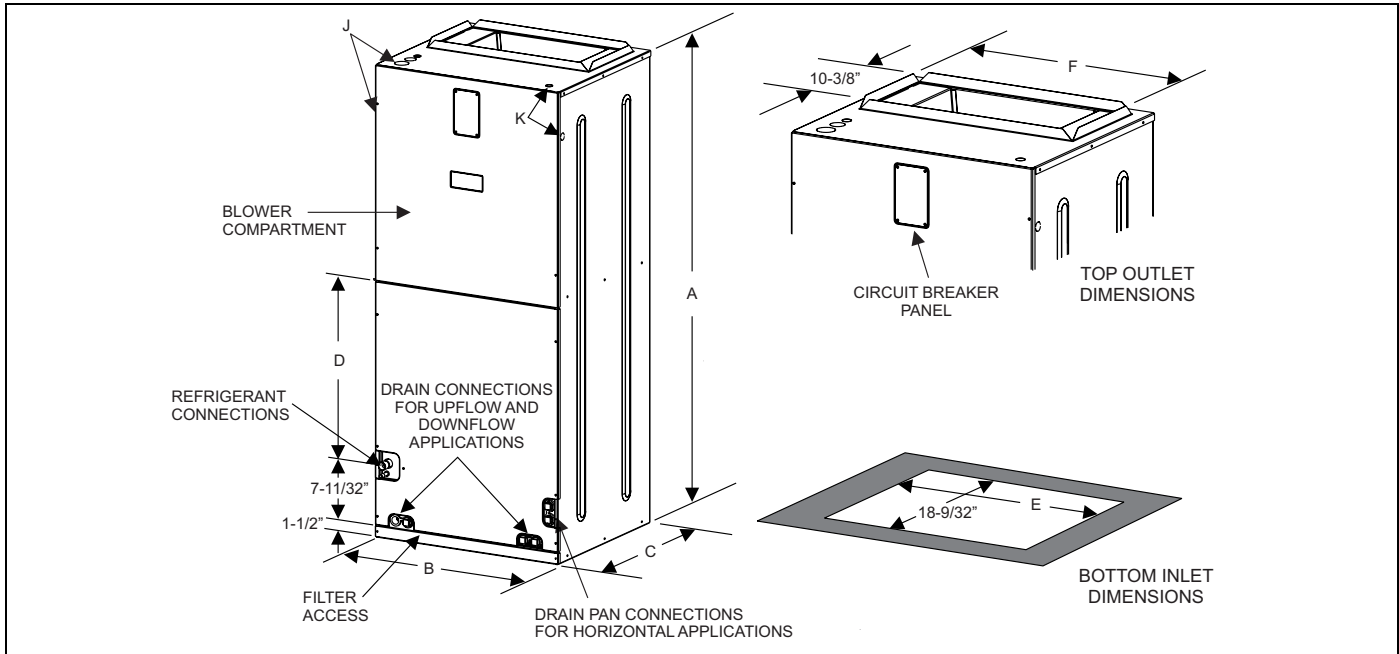

Dimensions

MODELS	Dimensions						Wiring Knockouts ¹		Refrigerant Connections Line Size	
	A	B	C	D	E	F	J	K	Liquid	Vapor
	Height	Width	Depth				Power	Control		
AHP18B3X(N,H)21 AHP18B2A(N,H)21 AHP18B4EH21	46	17.5	21.5	12-3/8	13-29/32	14-19/32	7/8" (1/2") 1 3/8" (1") 1 23/32" (1 1/4")	7/8" (1/2")	3/8"	3/4"
AHP24B3X(N,H)21 AHP24B2A(N,H)21 AHP24B4FH21	46	17.5		12-3/8	13-29/32	14-19/32	7/8" (1/2") 1 3/8" (1") 1 23/32" (1 1/4")	7/8" (1/2")	3/8"	3/4"
AHP30B3X(N,H)21 AHP30B2A(N,H)21 AHP30B4GH21 AHP30B4HH21 AHP30B4MH21	46	17.5		12-3/8	13-29/32	14-19/32	7/8" (1/2") 1 3/8" (1") 1 23/32" (1 1/4")	7/8" (1/2")	3/8"	3/4"
AHP36C3X(N,H)21 AHP36C2A(N,H)21 AHP36C4GH21 AHP36C4HH21 AHP36C4MH21	52	21		17-1/8	17-13/32	18-3/32	7/8" (1/2") 1 3/8" (1") 1 23/32" (1 1/4")	7/8" (1/2")	3/8"	7/8"
AHP42C3X(N,H)21 AHP42C2C(N,H)21 AHP42C4HH21	52	21		17-1/8	17-13/32	18-3/32	7/8" (1/2") 1 3/8" (1") 1 23/32" (1 1/4")	7/8" (1/2")	3/8"	7/8"
AHP48D3X(N,H)21 AHP48D2C(N,H)21 AHP48D4HH21 AHP48D4JH21	57	24.5		22-1/8	20-29/32	21-19/32	7/8" (1/2") 1 3/8" (1") 1 23/32" (1 1/4")	7/8" (1/2")	3/8"	7/8"
SHP48D3XN21 SHP48D2CN21	52	24.5		17-1/8	20-29/32	21-19/32				7/8"
AHP60D3X(N,H)21 AHP60D2C(N,H)21 AHP60D4JH21	57	24.5		22-1/8	20-29/32	21-19/32	7/8" (1/2") 1 3/8" (1") 1 23/32" (1 1/4")	7/8" (1/2")	3/8"	7/8"
SHP60D3XN21 SHP60D2CN21	52	24.5		17-1/8	20-29/32	21-19/32				7/8"

1. Actual size (Conduit size).
H indicates 4 position model.

COIL TECHNICAL DATA

Models	Application	Refrig. Conn. Types	Face Area (Sq. Ft.)	Rows Deep	Fin Per In.	Coil Size	Tube Geometry	Tube Dia.	Fin Type	TXV
AHP18B3X(N,H)21	Cooling / Heat Pump	Sweat	3.40	2	14	(2) 14 x 17.5	1 x 0.866	3/8	Enhanced	None
AHP18B2A(N,H)21										2A
AHP18B4EH21										4E
AHP24B3X(N,H)21	Cooling / Heat Pump	Sweat	3.89	2	14	(2) 16 x 17.5	1 x 0.866	3/8	Enhanced	None
AHP24B2A(N,H)21										2A
AHP24B4FH21										4F
AHP30B3X(N,H)21	Cooling / Heat Pump	Sweat	3.89	3	12	(2) 16 x 17.5	1 x 0.866	3/8	Enhanced	None
AHP30B2A(N,H)21										2A
AHP30B4GH21										4G
AHP30B4HH21										4H
AHP30B4MH21										4M
AHP36C3X(N,H)21	Cooling / Heat Pump	Sweat	4.86	3	12	(2) 20 x 17.5	1 x 0.866	3/8	Enhanced	None
AHP36C2A(N,H)21										2A
AHP36C4GH21										4G
AHP36C4HH21										4H
AHP36C4MH21										4M
AHP42C3X(N,H)21	Cooling / Heat Pump	Sweat	4.86	3	12	(2) 20 x 17.5	1 x 0.866	3/8	Enhanced	None
AHP42C2C(N,H)21										2C
AHP42C4HH21										4H
AHP48D3X(N,H)21	Cooling / Heat Pump	Sweat	5.83	3	11	(2) 24 x 17.5	1 x 0.866	3/8	Enhanced	None
AHP48D2C(N,H)21										2C
AHP48D4HH21										4H
AHP48D4JH21										4J
SHP48D3XN21										None
SHP48D2CN21										2C
AHP60D3X(N,H)21	Cooling / Heat Pump	Sweat	5.83	3	11	(2) 24 x 17.5	1 x 0.866	3/8	Enhanced	None
AHP60D2C(N,H)21										2C
AHP60D4JH21										4J
SHP60D3XN21										None
SHP60D2CN21										2C

Note: H models are available with a factory installed horizontal drain pan.

COOLING CAPACITY

Models	Rated CFM	Entering Air °F (Dry / Wet Bulb)	MBH@ Evaporator Temperature and Corresponding Pressure °F / PSIG			
			35 / 61.5	40 / 68.5	45 / 76.0	50 / 84.0
FULL-CASED "A" TYPE MULTI-POSITION						
AHP18B**(N,H)21	650	85/72	24.5	22.3	19.9	17.3
		80/67	22.6	20.3	18.0	15.6
		75/62	18.5	16.4	14.2	12.0
		70/57	15.0	13.1	10.9	8.5
AHP24B**(N,H)21	800	85/72	35.0	31.8	28.4	24.7
		80/67	32.2	29.1	25.7	22.3
		75/62	26.4	23.4	21.0	17.1
		70/57	21.4	18.6	20.2	12.1
AHP30B**(N,H)21	1050	85/72	41.5	37.8	33.7	29.5
		80/67	36.2	32.4	28.6	24.5
		75/62	29.1	25.3	24.0	19.2
		70/57	24.1	21.5	18.7	15.8
AHP36C**(N,H)21	1200	85/72	51.3	46.7	41.7	36.8
		80/67	41.1	36.3	31.8	27.1
		75/62	32.1	27.0	29.4	21.9
		70/57	27.6	25.4	23.5	18.3
AHP42C**(N,H)21	1400	85/72	88.4	76.0	63.3	50.0
		80/67	70.8	59.4	48.4	37.0
		75/62	55.2	43.9	35.8	29.9
		70/57	47.4	41.5	32.37	25.24
AHP48D**(N,H)21 SHP48D**N21	1600	85/72	100.5	86.4	72.0	56.8
		80/67	80.4	67.5	55.0	42.1
		75/62	62.7	49.9	40.7	34.0
		70/57	53.9	47.2	36.81	28.71
AHP60D**(N,H)21 SHP60D**N21	1850	85/72	119.9	101.0	82.0	62.2
		80/67	96.0	79.2	62.6	45.8
		75/62	74.8	58.6	46.2	37.0
		70/57	64.3	55.4	43.2	33.7

ACCESSORIES

Refer to Price Manual for specific model numbers.

TXV Kits - TXV kits are available for "Flex-coil" applications and converting R22 to R410A or as a service replacement. All kits are bolt-on and require no brazing to install.

Non-Combustible Bases - A combustible floor base accessory is available, if required by local codes, when the air handler is installed in the downflow position on a combustible material.

Electric Heaters - 4HK models shown under electrical data include sequential operation and temperature dual limit switches for safe, efficient operation. Circuit breakers are provided where shown.

External Insulating Wrap Kit - Provides a vinyl covered thermal insulation wrap, providing additional thermal insulation protection to prevent sweating in applications where extreme high humidity is present. Air Handler cover (or wrap) has Velcro edges for easy installation and access.

LIMITATIONS

These units must be wired and installed in accordance with all national and local safety codes.

Voltage limits are as follows:

Air Handler Voltage	Voltage code	¹ Normal Operating Voltage Range
208/230-1-60	06	187-253
220/240-1-50	93	198-264

1. Rated in accordance with ARI Standard 110, utilization range "A".

Airflow must be within the minimum and maximum limits approved for electric heat, evaporator coils and outdoor units.

Entering Air Temperature Limits			
Wet Bulb Temp. °F		Dry Bulb Temp. °F	
Min.	Max.	Min.	Max.
57	72	65	95

AIR FLOW DATA - 60 Hz MODELS

Models	Blower Motor Speed	208 Volt									
		CFM ¹ @ External Static Pressure - IWC									
		0.10	0.20	0.30	0.40	0.50	0.60	0.70	0.80	0.90	1.00
AHP18B**(N,H)21	High	1142	1096	1053	997	925	828	721	210	N/A	N/A
	Medium	677	652	634	615	572	486	295	120	N/A	N/A
	Low	442	427	395	361	289	209	114	N/A	N/A	N/A
AHP24B**(N,H)21	High	1084	1038	985	935	856	762	665	602	484	333
	Medium	840	807	767	693	610	550	485	387	323	221
	Low	654	614	548	483	420	349	302	218	179	130
AHP30B**(N,H)21	High	1244	1184	1138	1079	1004	903	841	674	580	457
	Medium	956	913	868	815	748	663	574	487	384	N/A
	Low	941	904	862	806	731	643	566	480	361	226
AHP36C**(N,H)21	High	1719	1650	1572	1482	1386	1273	1108	925	785	644
	Medium	1119	1097	1062	1019	935	827	743	637	479	337
	Low	929	910	877	825	760	685	616	508	372	221
AHP42C**(N,H)21	High	1719	1650	1572	1482	1386	1273	1108	925	785	644
	Medium	1119	1097	1062	1019	935	827	743	637	479	337
	Low	929	910	877	825	760	685	616	508	372	221
AHP48D**(N,H)21 SHP48D**N21	High	1941	1818	1675	1532	1269	870	703	362	146	N/A
	Medium	1594	1474	1409	1260	1021	802	524	215	144	N/A
	Low	1241	1204	1128	1014	819	659	385	165	N/A	N/A
AHP60D**(N,H)21 SHP60D**N21	High / #1	2126	2093	2074	2048	1991	1941	1801	1569	1461	1366
	Medium High / #2	1863	1842	1804	1800	1758	1730	1662	1503	1383	1306
	Medium / #3	1642	1603	1593	1568	1523	1471	1410	1334	1307	1216
	Medium Low / #4	1482	1468	1427	1370	1324	1274	1233	1196	1153	1099
	Low / #5	1268	1220	1169	1118	1070	1037	982.5	949.1	891.9	831

1. Includes return air filter and coil.

All Air handler units are UL Listed up to 0.50" w.c. external static pressure, including air filter, wet coil, and largest KW size heater, unless otherwise noted.

AIR FLOW DATA - 60 Hz MODELS

Models	Blower Motor Speed	230 Volt									
		CFM ¹ @ External Static Pressure - IWC									
		0.10	0.20	0.30	0.40	0.50	0.60	0.70	0.80	0.90	1.00
AHP18B**(N,H)21	High	1054	989	923	862	791	665	581	202	N/A	N/A
	Medium	782	762	716	670	613	536	315	121	N/A	N/A
	Low	541	519	479	445	397	298	168	N/A	N/A	N/A
AHP24B**(N,H)21	High	1232	1167	1098	1025	940	826	731	622	486	345
	Medium	966	915	868	799	724	641	540	452	347	224
	Low	785	740	684	618	532	446	364	296	192	131
AHP30B**(N,H)21	High	1434	1359	1297	1220	1138	1050	916	782	640	519
	Medium	1112	1076	1031	970	907	802	629	507	394	380
	Low	885	854	821	751	686	625	547	459	350	N/A
AHP36C**(N,H)21	High	1760	1681	1607	1538	1456	1360	1322	1260	966	770
	Medium	1320	1284	1255	1207	1146	1075	988	846	729	572
	Low	1146	1119	1090	1038	992	972	841	725	617	496
AHP42C**(N,H)21	High	1883	1764	1657	1543	1435	1327	1210	902	714	527
	Medium	1625	1510	1429	1339	1256	1172	1038	765	609	412
	Low	1260	1225	1179	1110	1047	973	785	638	500	340
AHP48D**(N,H)21 SHP48D**N21	High	2029	1944	1837	1743	1643	1537	1435	1320	1064	789
	Medium	1805	1730	1649	1566	1479	1385	1286	1147	851	683
	Low	1491	1441	1388	1328	1253	1174	1076	867	726	555
AHP60D**(N,H)21 SHP60D**N21	High / #1	2256	2226	2198	2159	2095	1959	1914	1776	1519	1380
	Medium High / #2	1990	1963	1935	1893	1857	1820	1783	1698	1486	1353
	Medium / #3	1774	1748	1704	1670	1635	1593	1534	1480	1384	1325
	Medium Low / #4	1557	1523	1483	1432	1389	1329	1265	1235	1198	1167
	Low / #5	1340	1300	1253	1198	1126	1079	1037	1007	954	912

1. Includes return air filter and coil.

All air handler units are UL Listed up to 0.50" w.c. external static pressure, including air filter, wet coil, and largest KW size heater, unless otherwise noted.

APPLICATION FACTORS - RATED CFM VS. ACTUAL CFM

% Of Rated Airflow	80%	90%	Rated CFM	110%	120%
Capacity Factor	0.96	0.98	1.00	1.02	1.03

PHYSICAL & ELECTRICAL DATA

Models		AHP18B**(N,H)21	AHP24B**(N,H)21	AHP30B**(N,H)21	AHP36C**(N,H)21
Blower - Diameter x Width		9 x 6	10 x 9	10 x 9	10 x 10
Motor	HP	1/3 HP	1/4 HP	1/2 HP	3/4 HP
	Nominal RPM	1075	1075	1075	1075
Voltage		230			
Amps	Full Load (230)	1.9	1.5	2.2	3.6
	Type	DISPOSABLE OR PERMANENT			
Filter ¹	Size	16 x 20 x 1	16 x 20 x 1	16 x 20 x 1	20 x 20 x 1
	Permanent Type Kit	1PF0601BK	1PF0601BK	1PF0601BK	1PF0602BK
Shipping / Operating Weight (lbs.) - N Models		128/122	132/126	139/133	162/156
Shipping / Operating Weight (lbs.) - H Models		131/125	135/129	142/136	165/159

Models		AHP42C**(N,H)21	AHP48D**(N,H)21 SHP48D**N21	AHP60D**(N,H)21 SHP60D**N21
Blower - Diameter x Width		10 x 10	10 x 10	11 x 10
Motor	HP	3/4 HP	3/4 HP	1 HP
	Nominal RPM	1075	1075	1050
Voltage		230		
Amps	Full Load (230)	3.8	3.8	7.6
	Type	DISPOSABLE OR PERMANENT		
Filter ¹	Size	20 x 20 x 1	22 x 20 x 1	22 x 20 x 1
	Permanent Type Kit	1PF0602BK	1PF0603BK	1PF0603BK
Shipping / Operating Weight (lbs.) - N Models		164/158	AHP - 186/175 SHP - 182/171	AHP - 189/178 SHP - 185 /174
Shipping / Operating Weight (lbs.) - H Models		167/161	190/179	193/182

1. Field Supplied.

ELECTRICAL DATA - COOLING ONLY (60 Hz)

Models	Total Motor Amps		Minimum Circuit Ampacity		Max. O.C.P.¹ Amps/Type	Minimum Wire Size A.W.G.
	60 Hertz		60 Hertz			
	208V	230V	208V	230V		
AHP18B**(N,H)21	1.7	1.9	2.1	2.4	15	14
AHP24B**(N,H)21	1.4	1.5	1.8	1.9	15	14
AHP30B**(N,H)21	2	2.2	2.5	2.8	15	14
AHP36C**(N,H)21	3.3	3.6	4.1	4.5	15	14
AHP42C**(N,H)21	3.4	3.8	4.3	4.8	15	14
AHP48D**(N,H)21	3.4	3.8	4.3	4.8	15	14
SHP48D**N21	3.4	3.8	4.3	4.8	15	14
AHP60D**(N,H)21	7.6	7.6	9.5	9.5	15	14
SHP60D**N21	7.6	7.6	9.5	9.5	15	14

1. OCP = Over Current Protection device, must be HACR type Circuit Breaker or Time Delay fuse.

ELECTRICAL DATA - 208/230-1-60

Models	Heater Models*	Max. Static	Min. Speed Tap	Total Heat ¹				kW Staging					
				kW		MBH		W1 Only		W2 Only		W1 + W2	
				208V	240V	208V	240V	208V	240V	208V	240V	208V	240V
AHP18B**(N,H)21	4HK*6500206	0.5	Lo	1.9	2.5	6.4	8.5	1.9	2.5	1.9	2.5	1.9	2.5
	4HK*6500506	0.5	Med	3.6	4.8	12.3	16.4	3.6	4.8	3.6	4.8	3.6	4.8
	4HK*6500806	0.5	Med	5.6	7.5	19.2	25.6	2.8	3.75	5.6	7.5	5.6	7.5
AHP24B**(N,H)21	4HK*6500206	0.5	Lo	1.9	2.5	6.4	8.5	1.9	2.5	1.9	2.5	1.9	2.5
	4HK*6500506	0.5	Lo	3.6	4.8	12.3	16.4	3.6	4.8	3.6	4.8	3.6	4.8
	4HK*6500806	0.5	Med	5.6	7.5	19.2	25.6	2.8	3.75	5.6	7.5	5.6	7.5
	4HK*6501006	0.5	Hi	7.2	9.6	24.6	32.8	3.6	4.8	7.2	9.6	7.2	9.6
	4HK16501306	0.5	Hi	9.8	13.0	33.3	44.4	3.3	4.3	6.5	8.6	9.8	13.0
AHP30B**(N,H)21	4HK*6500506	0.5	Lo	3.6	4.8	12.3	16.4	3.6	4.8	3.6	4.8	3.6	4.8
	4HK*6500806	0.5	Med	5.6	7.5	19.2	25.6	2.8	3.75	5.6	7.5	5.6	7.5
	4HK*6501006	0.5	Hi	7.2	9.6	24.6	32.8	3.6	4.8	7.2	9.6	7.2	9.6
	4HK16501306	0.5	Hi	9.8	13.0	33.3	44.4	3.3	4.3	6.5	8.6	9.8	13.0
	4HK165N1506	0.4 ²	Hi	10.8	14.4	36.9	49.1	3.6	4.8	7.2	9.6	10.8	14.4
AHP36C**(N,H)21	4HK*6500506	0.5	Lo	3.6	4.8	12.3	16.4	3.6	4.8	3.6	4.8	3.6	4.8
	4HK*6500806	0.5	Med	5.6	7.5	19.2	25.6	2.8	3.75	5.6	7.5	5.6	7.5
	4HK*6501006	0.5	Med	7.2	9.6	24.6	32.8	3.6	4.8	7.2	9.6	7.2	9.6
	4HK16501506	0.5	Med	10.8	14.4	36.9	49.1	3.6	4.8	7.2	9.6	10.8	14.4
	4HK16501806	0.5	Hi	13.2	17.6	45.1	60.1	3.3	4.4	6.6	8.8	13.2	17.6
AHP42C**(N,H)21	4HK*6500506	0.5	Lo	3.6	4.8	12.3	16.4	3.6	4.8	3.6	4.8	3.6	4.8
	4HK*6500806	0.5	Med	5.6	7.5	19.2	25.6	2.8	3.75	2.8	7.5	5.6	7.5
	4HK*6501006	0.5	Med	7.2	9.6	24.6	32.8	3.6	4.8	7.2	9.6	7.2	9.6
	4HK16501506	0.5	Med	10.8	14.4	36.9	49.1	3.6	4.8	7.2	9.6	10.8	14.4
	4HK16501806	0.5	Hi	13.2	17.6	45.1	60.1	3.3	4.4	6.6	8.8	13.2	17.6
	4HK16502006	0.5	Hi	14.4	19.2	49.2	65.5	3.6	4.8	7.2	9.6	14.4	19.2
AHP48D**(N,H)21 SHP48D**N21	4HK*6500506	0.5	Lo	3.6	4.8	12.3	16.4	3.6	4.8	3.6	4.8	3.6	4.8
	4HK*6500806	0.5	Med	5.6	7.5	19.2	25.6	2.8	3.75	2.8	7.5	5.6	7.5
	4HK*6501006	0.5	Med	7.2	9.6	24.6	32.8	3.6	4.8	7.2	9.6	7.2	9.6
	4HK16501506	0.5	Med	10.8	14.4	36.9	49.1	3.6	4.8	7.2	9.6	10.8	14.4
	4HK16501806	0.5	Hi	13.2	17.6	45.1	60.1	3.3	4.4	6.6	8.8	13.2	17.6
	4HK16502006	0.5	Hi	14.4	19.2	49.2	65.5	3.6	4.8	7.2	9.6	14.4	19.2
AHP60D**(N,H)21 SHP60D**N21	4HK*6500506	0.5	MedLow/#4	3.6	4.8	12.3	16.4	3.6	4.8	3.6	4.8	3.6	4.8
	4HK*6500806	0.5	MedLow/#4	5.6	7.5	19.2	25.6	2.8	3.75	2.8	7.5	5.6	7.5
	4HK*6501006	0.5	Med/#3	7.2	9.6	24.6	32.8	3.6	4.8	7.2	9.6	7.2	9.6
	4HK16501506	0.5	MedHigh/#2	10.8	14.4	36.9	49.1	3.6	4.8	7.2	9.6	10.8	14.4
	4HK16501806	0.5	MedHigh/#2	13.2	17.6	45.1	60.1	3.3	4.4	6.6	8.8	13.2	17.6
	4HK16502006	0.5	MedHigh/#2	14.4	19.2	49.2	65.5	3.6	4.8	7.2	9.6	14.4	19.2
	4HK16502506	0.5	MedHigh/#2	18.0	24.0	61.5	81.9	3.6	4.8	10.8	14.4	18.0	24

1. See conversion table below.
 2. AHP30B w/4HK165N1506 only approved for use up to .4" static.
- * May be 0 (no breaker) or 1 (with breaker).

kW & MBH CONVERSIONS - FOR TOTAL POWER INPUT REQUIREMENT

FOR	208V	OPERATION MULTIPLY	240V	TABULATED kW & MBH BY	.751
	230V		240V		.918

ELECTRICAL DATA (FOR SINGLE SOURCE POWER SUPPLY) - COPPER WIRE 208/230-1-60

Models	Heater Models*	Heater Amps 240V	Field Wiring					
			Min. Circuit Ampacity		Max. O.C.P. ¹ Amps/Type		75°C Wire Size - AWG	
			208V	240V	208V	240V	208V	240V
AHP18B**(N,H)21	4HK*6500206	10.4	13.5	15.4	15	20	12	12
	4HK*6500506	20.0	23.8	27.4	25	30	10	10
	4HK*6500806	31.3	36.0	41.5	40	45	8	8
AHP24B**(N,H)21	4HK*6500206	10.4	13.0	14.9	15	15	12	12
	4HK*6500506	20.0	23.4	26.9	25	30	10	10
	4HK*6500806	31.3	35.6	41.0	40	45	8	8
	4HK*6501006	40.0	45.1	51.9	45	60	8	6
	4HK16501306	54.2	60.4	69.6	70	70	4	4
AHP30B**(N,H)21	4HK*6500506	20.0	24.2	27.8	25	30	10	10
	4HK*6500806	31.3	36.4	41.9	40	45	8	8
	4HK*6501006	40.0	45.8	52.8	50	60	8	6
	4HK16501306	54.2	60.1	70.5	70	90	4	3
	4HK165N1506	60.0	67.5	77.8	70	90	4	3
AHP36C**(N,H)21	4HK*6500506	20.0	25.8	29.5	30	30	10	10
	4HK*6500806	31.3	38.0	43.6	40	45	8	8
	4HK*6501006	40.0	47.5	54.5	50	60	8	6
	4HK16501506	60.0	69.1	79.5	70	90	4	3
	4HK16501806	73.3	83.6	96.1	90	100	3	3
AHP42C**(N,H)21	4HK*6500506	20.0	25.9	29.8	30	30	8	8
	4HK*6500806	31.3	38.1	43.9	40	45	8	8
	4HK*6501006	40.0	47.6	54.8	50	60	6	6
	4HK16501506	60.0	69.3	79.8	70	90	4	3
	4HK16501806	73.3	83.7	96.4	90	100	3	3
	4HK16502006	80.0	90.9	104.8	100	110	3	2
AHP48D**(N,H)21 SHP48D**N21	4HK*6500506	20.0	25.9	29.8	30	30	10	10
	4HK*6500806	31.3	38.1	43.9	40	45	8	8
	4HK*6501006	40.0	47.6	54.8	50	60	8	6
	4HK16501506	60.0	69.3	79.8	70	90	4	3
	4HK16501806	73.3	83.7	96.4	90	100	3	3
	4HK16502006	80.0	90.9	104.8	100	110	3	2
AHP60D**(N,H)21 SHP60D**N21	4HK*6500506	20.0	31.2	34.5	35	35	8	8
	4HK*6500806	31.3	43.4	48.6	45	50	8	8
	4HK*6501006	40.0	52.8	59.5	60	60	6	6
	4HK16501506	60.0	74.5	84.5	90	90	3	3
	4HK16501806	73.3	88.9	101.1	90	110	3	2
	4HK16502006	80.0	96.2	109.5	100	125	3	1
	4HK16502506	100.0	117.8	134.5	125	150	1	1/0

1. O.C.P. = Over Current Protection device, must be HACR type Circuit Breaker or Time Delay fuse.

* May be 0 (no breaker) or 1 (with breaker).

ELECTRICAL DATA (FOR MULTI SOURCE POWER SUPPLY) - COPPER WIRE 208/230-1-60

Models	Heater Models	Min. Circuit Ampacity			Max. O.C.P. ¹ Amps/Type			75°C Wire Size - AWG		
		Circuit			Circuit			Circuit		
		1st	2nd	3rd	1st	2nd	3rd	1st	2nd	3rd
		208/240	208/240	208/240	208/240	208/240	208/240	208/240	208/240	208/240
AHP24B**(N,H)21	4HK16501306	40.9/47.0	19.5/22.5	–	45/50	20/25	–	8/8	10/10	–
AHP30B**(N,H)21	4HK16501306	41.6/47.9	19.5/22.5	–	45/50	20/25	–	8/8	10/10	–
	4HK165N1506	45.8/52.8	21.7/25.0	–	50/60	25/25	–	8/6	10/10	–
AHP36C**(N,H)21	4HK16501506	47.5/54.5	21.7/25.0	–	50/60	25/25	–	8/6	10/10	–
	4HK16501806	43.9/50.3	39.8/45.8	–	45/60	40/50	–	8/6	8/8	–
AHP42C**(N,H)21	4HK16501506	47.6/54.8	21.7/25.0	–	50/60	25/25	–	8/6	10/10	–
	4HK16501806	44.0/50.6	39.8/45.8	–	45/60	40/50	–	8/6	8/8	–
	4HK16502006	47.6/54.8	43.4/50.0	–	50/60	40/50	–	8/6	8/8	–
AHP48D**(N,H)21 SHP48D**N21	4HK16501506	47.6/54.8	21.7/25.0	–	50/60	25/25	–	8/6	10/10	–
	4HK16501806	44.0/50.6	39.8/45.8	–	45/60	40/50	–	8/6	8/8	–
	4HK16502006	47.6/54.8	43.4/50.0	–	50/60	40/50	–	8/6	8/8	–
AHP60D**(N,H)21 SHP60D**N21	4HK16501506	52.9/59.5	21.7/25.0	–	60/60	25/25	–	6/6	10/10	–
	4HK16501806	49.3/55.3	39.8/45.8	–	50/60	45/60	–	6/6	8/6	–
	4HK16502006	52.9/59.5	43.4/50.0	–	60/60	45/50	–	6/6	8/8	–
	4HK16502506	52.9/59.5	43.4/50.0	21.68/25.00	60/60	45/50	25/25	6/6	8/8	10/10

1. O.C.P. = Over Current Protection device, must be HACR type Circuit Breaker or Time Delay fuse.

ELECTRICAL DATA - 208/230-3-60

Models	Heat Kit - Three Phase	Max. Static	Min. Speed Tap	Total Heat ¹				KW Staging					
				KW		MBH		W1 Only		W2 Only		W1 + W2	
				208V	240V	208V	240V	208V	240V	208V	240V	208V	240V
AHP24B**(N,H)21	4HK06501025	0.5	Hi	7.2	9.6	24.6	32.8	7.2	9.6	7.2	9.6	7.2	9.6
AHP30B**(N,H)21	4HK06501025	0.5	Hi	7.2	9.6	24.6	32.8	7.2	9.6	7.2	9.6	7.2	9.6
	4HK065N1525	0.5	Hi	10.8	14.4	36.9	49.1	10.8	14.4	10.8	14.4	10.8	14.4
AHP36C**(N,H)21	4HK06501025	0.5	Med	7.2	9.6	24.6	32.8	7.2	9.6	7.2	9.6	7.2	9.6
	4HK06501525	0.5	Med	10.8	14.4	36.9	49.1	10.8	14.4	10.8	14.4	10.8	14.4
AHP42C**(N,H)21	4HK06501025	0.5	Med	7.2	9.6	24.6	32.8	7.2	9.6	7.2	9.6	7.2	9.6
	4HK06501525	0.5	Med	10.8	14.4	36.9	49.1	10.8	14.4	10.8	14.4	10.8	14.4
	4HK06501825	0.5	Hi	12.9	17.2	44.7	58.7	12.9	17.2	12.9	17.2	12.9	17.2
AHP48D**(N,H)21 SHP48D**N21	4HK06501025	0.5	Med	7.2	9.6	24.6	32.8	7.2	9.6	7.2	9.6	7.2	9.6
	4HK06501525	0.5	Med	10.8	14.4	36.9	49.1	10.8	14.4	10.8	14.4	10.8	14.4
	4HK06501825	0.5	Hi	12.9	17.2	44.7	58.7	12.9	17.2	12.9	17.2	12.9	17.2
AHP60D**(N,H)21 SHP60D**N21	4HK06501025	0.5	Med/#3	7.2	9.6	24.6	32.8	7.2	9.6	7.2	9.6	7.2	9.6
	4HK06501525	0.5	MedHigh/#2	10.8	14.4	36.9	49.1	10.8	14.4	10.8	14.4	10.8	14.4
	4HK06501825	0.5	MedHigh/#2	12.9	17.2	44.7	58.7	12.9	17.2	12.9	17.2	12.9	17.2
	4HK16502525	0.5	MedHigh/#2	18.0	24.0	61.4	81.4	9.0	12.0	18.0	24.0	18.0	24.0

1. See conversion table on Page 7.

ELECTRICAL DATA (FOR SINGLE SOURCE POWER SUPPLY) - COPPER WIRE 208/230-3-60

Models	Heat Kit - Three Phase	Heater Amps 240V	Field Wiring					
			Min. Circuit Ampacity		Max. O.C.P. ¹ Amps/Type		75°C Wire Size - AWG	
			208V	240V	208V	240V	208V	240V
AHP24B**(N,H)21	4HK06501025	23.1	27.1	31.3	30	35	10	8
AHP30B**(N,H)21	4HK06501025	23.1	26.8	30.8	30	35	10	8
	4HK065N1525	34.7	40.0	46.1	40	50	8	8
AHP36C**(N,H)21	4HK06501025	23.1	27.5	31.6	30	35	10	8
	4HK06501525	34.7	40.0	46.1	40	50	8	8
AHP42C**(N,H)21	4HK06501025	23.1	29.1	33.4	30	35	10	8
	4HK06501525	34.7	41.6	47.9	50	50	8	8
	4HK06501825	41.4	48.9	56.3	50	60	8	6
AHP48D**(N,H)21 SHP48D**N21	4HK06501025	23.1	29.3	33.6	30	35	10	8
	4HK06501525	34.7	41.8	48.1	50	50	8	8
	4HK06501825	41.4	49.0	56.5	50	60	8	6
AHP60D**(N,H)21 SHP60D**N21	4HK06501025	23.1	34.5	38.4	35	40	8	8
	4HK06501525	34.7	47.0	52.9	50	60	8	6

1. O.C.P. = Over Current Protection device, must be HACR type Circuit Breaker or Time Delay fuse.
2. Heaters are 3 Phase.

ELECTRICAL DATA (FOR MULTI SOURCE POWER SUPPLY) - COPPER WIRE 208/230-3-60

Models	Heater Model	Minimum Circuit Ampacity			Max. O.C.P. ¹ Amps/Type			75°C Wire Size - AWG		
		Circuit								
		1st	2nd	3rd	1st	2nd	3rd	1st	2nd	3rd
AHP60D**(N,H)21 SHP60D**N21	4HK16501825	31.9/35.4	22.4/25.9	—/—	35/40	25/30	—/—	8/8	10/10	—/—
	4HK16502525	40.8/45.6	31.3/36.1	—/—	45/50	35/40	—/—	8/8	8/8	—/—

1. O.C.P. = Over Current Protection device, must be HACR type Circuit Breaker or Time Delay fuse.

COOLING MODELS WITH ELECTRIC HEAT WIRING

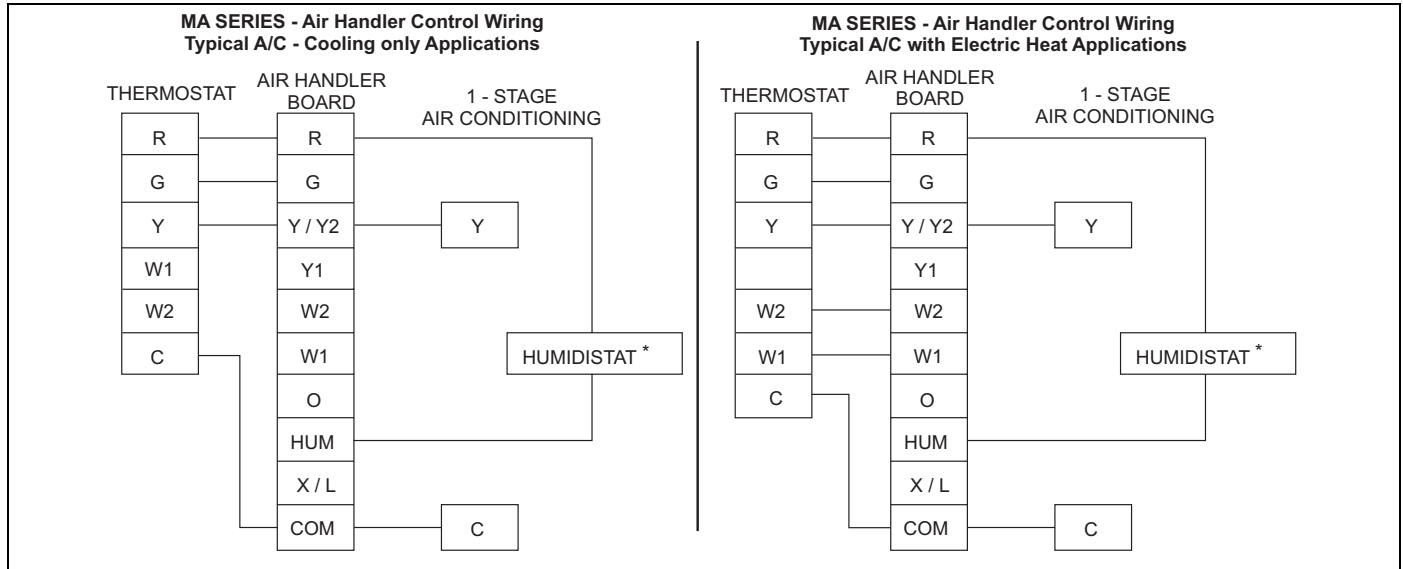

COOLING MODELS WITH ELECTRIC HEAT WIRING

* Optional dehumidification humidistat switch contacts open on humidity rise.

Notes:

1. "Y" Terminal on Air Handler Control Board must be connected for full CFM and applications requiring 60 second blower off delay for SEER enhancement.
2. Move HUM STAT Jumper on AH Control Board to YES position if Humidistat is used.
3. MODE Jumper on AH control board should be set to A/C for air conditioners.

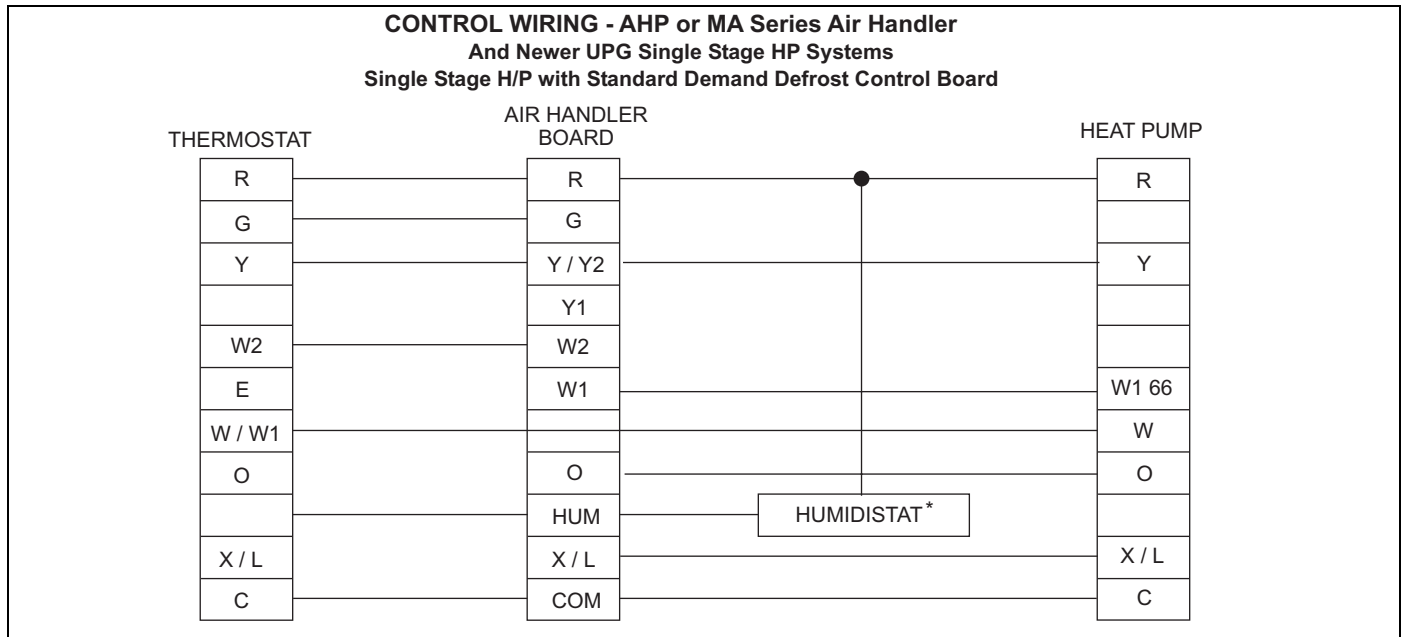

SINGLE-STAGE COOLING WIRING

* Optional dehumidification humidistat switch contacts open on rise.

Notes:

1. "Y" Terminal on Air Handler Control Board must be connected for full CFM and applications requiring 60 second blower off delay for SEER enhancement.
2. Move HUM STAT Jumper on AH Control Board to YES/NO position.
3. MODE Jumper on AH control board should be set to HP for heat pumps.
4. To change quantity of heat during HP defrost cycle - Reverse connections at W1 & W2 on Air Handler Control Board.

TYPICAL APPLICATIONS

