



TECHNICAL GUIDE

80% MODULATING (PSC MOTOR) GAS-FIRED RESIDENTIAL MULTI-POSITION GAS FURNACES STANDARD & Low NOx MODELS

MODELS: YM8M / YMLM

NATURAL GAS
60 - 120 MBH INPUT



Due to continuous product improvement, specifications are subject to change without notice.

Visit us on the web at www.york.com for the most up-to-date technical information.

Additional efficiency rating information can be found at www.gamanet.org.

DESCRIPTION

These compact units employ induced combustion, reliable hot surface ignition and high heat transfer aluminized tubular heat exchangers. The units are factory shipped for installation in upflow or horizontal applications and may be converted for downflow applications.

These furnaces are designed for residential installation in a basement, closet, alcove, attic, recreation room or garage and are also ideal for commercial applications. All units are factory assembled, wired and tested to assure safe dependable and economical installation and operation.

These units are Category I listed and may be common vented with another gas appliance as allowed by the National Fuel Gas Code.

WARRANTY

Lifetime limited warranty on heat exchanger to the original purchaser; a 20-year limited warranty from original installation date to subsequent purchaser.

10-year warranty on the heat exchanger in commercial applications.

5-year limited parts warranty.

FEATURES

- Modulating heating operation includes:
 - Modulating gas valve, inducer and circulating blower.
 - Modulating operation from 100% input to 50% input in 1% increments.
- Easily applied in upflow, horizontal left or right, or downflow installation with minimal conversion necessary.
- Compact, easy to install, ideal height 33" tall cabinet.
- Blower-off delay for cooling SEER improvement.
- Easy access to controls to connect power/control wiring.
- Built-in, high level self diagnostics with fault code display.
- Low unit amp requirement for easy replacement application.
- All models are convertible to use propane (LP) gas.
- Electronic Hot Surface Ignition saves fuel cost with increased dependability and reliability.
- 100% shut off main gas valve for extra safety.
- High-efficiency variable speed direct drive motor.
- 24V, 40 VA control transformer and blower relay supplied for add-on cooling.
- Hi-tech tubular aluminized steel primary heat exchanger.
- Blower door safety switch.
- Solid removable bottom panel allows easy conversion.
- Low NOx models have been designed to meet specific code requirements.
- Airflow leakage less than 1% of nominal airflow for ductblaster conditions.
- No knockouts to deal with, making installation easier.
- Movable duct connector flanges for application flexibility.
- Quiet inducer operation.
- Inducer rotates for easy conversion of venting options.
- Fully supported blower assembly for easy access and removal of blower.
- External air filters used for maximum flexibility in meeting customers IAQ needs.
- Venting applications - may be installed as a common vent with other gas-fired appliances.
- Insulated blower compartment for quiet operation.
- 1/4 turn knobs provided for easy door removal.

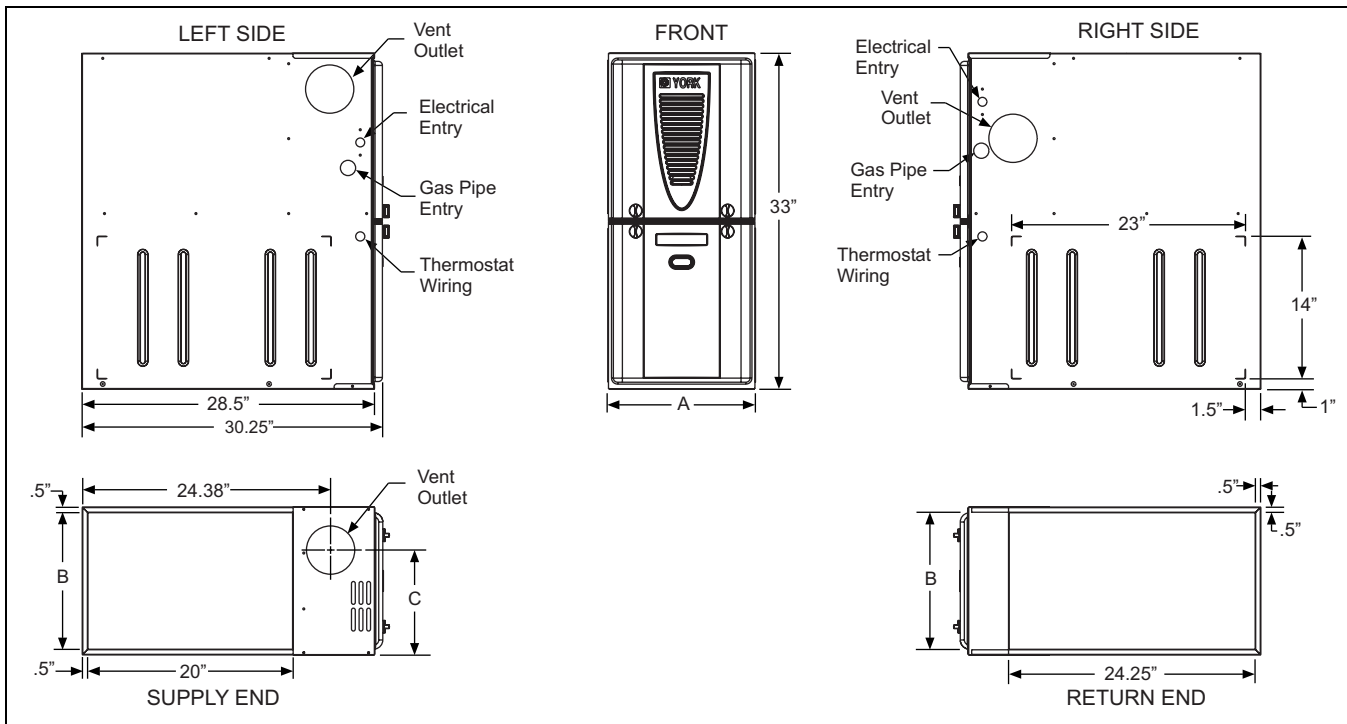

Cabinet and Duct Dimensions

Models	Nominal CFM (m ³ /min)	Cabinet Size	Cabinet Dimensions (Inches)			Approximate Operating Weights
			A	B	C	Lbs
YM(8,L)M060A12MP11	1200	A	14 1/2	13 1/4	10.3	94
YM(8,L)M080B12MP11	1200	B	17 1/2	16 1/4	11.8	103
YM(8,L)M080C16MP11	1600	C	21	19 3/4	13.6	114
YM(8,L)M100C16MP11	1600	C	21	19 3/4	13.6	118
YM(8,L)M100C20MP11	2000	C	21	19 3/4	13.6	122
YM(8,L)M120C20MP11	2000	C	21	19 3/4	15.8	129

Ratings & Physical / Electrical Data

Models	Input Max/Min	Output Max/Min	Nominal Airflow	Total Unit Amps	AFUE	Air Temp. Rise Max Input	Air Temp. Rise Min Input	Max Over-Current Protect	Min. wire Size (awg) @ 75 ft one way	Max. Outlet Air Temp
	MBH	MBH	CFM			°F	°F			°F
YM(8,L)M060A12MP11	60/30	48/24	1200	7.0	80.0	35-65	20-50	15	14	165
YM(8,L)M080B12MP11	80/40	64/32	1200	7.5	80.0	40-70	20-50	15	14	170
YM(8,L)M080C16MP11	80/40	64/32	1600	10.0	80.0	40-70	20-50	15	14	170
YM(8,L)M100C16MP11	100/50	80/40	1600	10.0	80.0	40-70	20-50	15	14	170
YM(8,L)M100C20MP11	100/50	80/40	2000	17.0	80.0	35-65	20-50	20	12	165
YM(8,L)M120C20MP11	120/60	96/48	2000	17.0	80.0	45-75	25-55	20	12	175

Annual Fuel Utilization Efficiency (AFUE) numbers are determined in accordance with DOE Test procedures. Wire size and over current protection must comply with the National Electrical Code (NFPA-70-latest edition) and all local codes.

FILTER PERFORMANCE

The airflow capacity data published in the “Blower Performance” table represents blower performance WITHOUT filters.

All applications of these furnaces require the use of field installed air filters. All filter media and mounting hardware or provisions must be field installed external to the furnace cabinet. DO NOT attempt to install any filters inside the furnace.

NOTE: Single side return above 1800 CFM is approved as long as the filter velocity does not exceed filter manufacturer’s recommendation and a transition is used to allow use of a 20 x 25 filter.

Recommended Filter Sizes

CFM	Cabinet Size	Side (in)	Bottom (in)
1200	A	16 x 25	14 x 25
1200	B	16 x 25	16 x 25
1600	C	16 x 25	20 x 25
2000	C	(2) 16 x 25	20 x 25

NOTES:

- Air velocity through throwaway type filters may not exceed 300 feet per minute (91.4 m/min). All velocities over this require the use of high velocity filters.
- Do not exceed 1800 CFM using a single side return and a 16x25 filter. For CFM greater than 1800, you may use two side returns or one side and the bottom or one return with a transition to allow use of a 20x25 filter.

Unit Clearances to Combustibles

Application	Top	Front	Rear	Left Side	Right Side	Flue	Floor/Bottom	Closet	Alcove	Attic	Line Contact
Upflow B-Vent	1	3	0	0	0	1	Combustible	Yes	Yes	Yes	No
Downflow B-Vent	1	3	0	0	0	1	1 ¹	Yes	Yes	Yes	No
Horizontal B-Vent	1	3	0	0	0	1	Combustible	No	Yes	Yes	Yes ²

1. Special floor base or air conditioning coil required for use on floor.

2. Line contact only permitted between lines formed by the intersection of the rear panel and side panel (top in horizontal position) of the furnace jacket and building joists, studs or framing.

ACCESSORIES

PROPANE (LP) CONVERSION KIT -

1NP0680 - All Models

This accessory conversion kit may be used to convert natural gas (N) units for propane (LP) operation.

SIDE RETURN FILTER RACKS -

1SR0200 - All Models

1SR0302 - All Models

1SF0101 - All Models

BOTTOM RETURN FILTER RACKS -

1BR0514 or 1BR0614 - For 14-1/2” cabinets

1BR0517 or 1BR0617 - For 17-1/2” cabinets

1BR0521 or 1BR0621 - For 21” cabinets

1BR05xx series are galvanized steel filter racks. 1BR06xx are pre-painted steel filter racks to match the appearance of the furnace cabinet.

COMBUSTIBLE FLOOR BASE KIT -

For installation of these furnaces in downflow applications directly onto combustible flooring material, These kits are required to prevent potential overheating situations. These kits are also required in any applications where the furnace is installed in a downflow configuration without an evaporator coil, where the combustible floor base kit provides access for combustible airflow.

1CB0514 - For 14-1/2” cabinets

1CB0517 - For 17-1/2” cabinets

1CB0521 - For 21” cabinets

EAC TRANSITION KITS -

For installation of EAC accessories with these furnaces to provide easy transition of return airflow through the EAC to get the proper sealing and reduced airflow leakage.

1TK1001 - For all models using side return

1TK1014 - For 14-1/2” cabinets using bottom return

1TK1017 - For 17-1/2” cabinets using bottom return

1TK1021 - For 21” cabinets using bottom return

1TK1024 - For 24-1/2” cabinets using bottom return

HIGH ALTITUDE - No high altitude kits are required.

ROOM THERMOSTATS - A wide selection of compatible thermostats are available to provide optimum performance and features for any installation.

1H/1C, manual change-over electronic non-programmable thermostat.

1H/1C, auto/manual changeover, electronic programmable, deluxe 7-day, thermostat.

1H/1C, auto/manual changeover, electronic programmable.

* For the most current accessory information, refer to the price book or consult factory.

Blower Performance CFM - Any Position

Bottom Airflow Return (SCFM) (without filter)											
Models	Speed	Ext. Static Pressure (in. H2O)									
		0.1	0.2	0.3	0.4	0.5	0.6	0.7	0.8	0.9	1.0
YM(8,L)M060A12MP11	High	1358	1341	1319	1303	1275	1238	1190	1130	1062	943
	Medium High	1097	1083	1075	1064	1042	1024	997	962	906	821
	Medium Low	935	928	920	899	872	840	809	771	731	659
	Low	800	779	763	736	711	687	657	622	584	529
YM(8,L)M080B12MP11	High	1320	1327	1307	1281	1243	1197	1143	1075	1003	881
	Medium High	1003	981	975	954	926	895	865	824	751	687
	Medium Low	821	818	809	786	758	726	690	631	594	534
	Low	674	652	624	599	566	531	494	451	394	354
YM(8,L)M080C16MP11	High	1881	1822	1783	1696	1602	1539	1465	1394	1267	1130
	Medium High	1553	1535	1492	1456	1408	1343	1279	1226	1113	1014
	Medium Low	1312	1286	1288	1260	1205	1143	1091	1029	966	841
	Low	1169	1166	1128	1098	1069	1032	987	909	835	747
YM(8,L)M100C16MP11	High	2069	2014	1956	1885	1820	1748	1668	1577	1468	1362
	Medium High	1662	1656	1639	1608	1586	1544	1491	1421	1338	1204
	Medium	1368	1371	1377	1376	1367	1334	1295	1250	1188	1104
	Low	1016	1014	1018	1030	1012	996	975	944	898	852
YM(8,L)M100C20MP11	High	2764	2695	2618	2552	2432	2337	2228	2109	1954	1808
	Medium High	2028	2009	1976	1910	1871	1830	1749	1679	1573	1473
	Medium Low	1613	1600	1543	1533	1482	1433	1384	1316	1252	1160
	Low	1297	1277	1245	1213	1175	1129	1077	1011	925	837
YM(8,L)M120C20MP11	High	2701	2620	2533	2429	2338	2227	2112	1993	1861	1706
	Medium High	2125	2083	2046	1994	1955	1901	1857	1737	1621	1497
	Medium Low	1664	1664	1547	1619	1580	1554	1468	1392	1331	1226
	Low	1357	1339	1330	1318	1286	1235	1185	1141	1060	938
Left Side Airflow Return (SCFM) - Upflow (without filter)											
YM(8,L)M060A12MP11	High	1244	1229	1226	1215	1196	1177	1143	1072	1015	940
	Medium High	1129	1126	1107	1094	1076	1047	1010	966	921	843
	Medium Low	970	947	933	916	890	863	827	789	741	668
	Low	834	809	797	768	740	710	677	634	586	534
YM(8,L)M080B12MP11	High	1274	1285	1255	1239	1207	1158	1111	1049	979	830
	Medium High	975	974	968	960	948	923	879	823	756	672
	Medium Low	777	771	772	762	752	734	695	651	604	529
	Low	647	634	623	610	602	588	552	506	457	381
YM(8,L)M080C16MP11	High	1825	1781	1746	1695	1641	1587	1521	1429	1330	1184
	Medium High	1516	1493	1482	1464	1442	1411	1343	1275	1192	1035
	Medium	1294	1297	1271	1238	1187	1120	1083	1028	979	851
	Low	1126	1115	1095	1049	1027	996	957	929	840	742
YM(8,L)M100C16MP11	High	2009	1994	1933	1893	1836	1763	1691	1606	1508	1389
	Medium High	1523	1506	1521	1490	1466	1435	1393	1326	1241	1119
	Medium Low	1230	1249	1245	1230	1218	1195	1161	1120	1039	949
	Low	1126	1115	1095	1049	1027	996	957	929	840	742
YM(8,L)M100C20MP11	High	2817	2774	2712	2620	2551	2465	2375	2266	2131	1992
	Medium High	1958	1946	1924	1901	1850	1813	1752	1675	1598	1502
	Medium Low	1539	1523	1519	1491	1449	1395	1351	1270	1197	1098
	Low	1276	1218	1229	1178	1126	1084	1017	958	890	819
YM(8,L)M120C20MP11	High	2828	2768	2699	2612	2524	2423	2308	2219	2118	1982
	Medium High	2085	2073	2042	2029	1967	1896	1893	1816	1717	1635
	Medium Low	1620	1631	1636	1593	1567	1557	1520	1476	1407	1263
	Low	1322	1311	1302	1271	1241	1201	1162	1101	1042	979

NOTES:

1. Airflow expressed in standard cubic feet per minute (CFM).
2. Return air is through side opposite motor (left side).
3. Motor voltage at 115 V.
4. Airflow through across motor side (right side) may be slightly less than the data shown above.

Subject to change without notice. Printed in U.S.A.
 Copyright © 2008 by Johnson Controls, Inc. All rights reserved.

402695-YTG-A-0508
 Supersedes: Nothing

Johnson Controls Unitary Products
5005 York Drive
Norman, OK 73069