

TE-6800 Series Temperature Sensors

TE-68xx-xNN0S Installation Instructions

Applications

The TE-68xx-xNN0S Series provides temperature sensing in room wall mount applications. It allows local setpoint temperature adjustment and temporary occupancy override.

A warmer/cooler dial is included on certain models for minor temperature adjustments from the setpoint. An occupancy override button is also featured on some models, which allows the user to signal the controller that the space is occupied, to request an override of time-of-day scheduling. Select models include DIP switches to enable or disable unit functions.

Depending on the model chosen, the wires connecting the sensor to the controller can be terminated using a screw terminal block, offering wiring flexibility.

IMPORTANT: Use the TE-6800 Series Temperature Sensor only to provide input to equipment under normal operating conditions. Where failure or malfunction of the TE-6800 Series element could lead to personal injury or property damage to the controlled equipment or other property, additional precautions must be designed into the control system. Incorporate and maintain other devices, such as supervisory or alarm systems or safety or limit controls intended to warn of, or protect against, failure or malfunction of the TE-6800 Series.

Installation

Special Tools Needed

A 1/16 in. (1.5 mm) hex wrench or a T-4000-119 hex-head adjustment tool is required during installation.

Mounting

Location Considerations

Locate the TE-6800 sensor:

- on a partitioning interior wall, and approximately 5 ft (1.5 m) above the floor in a location of average temperature
- away from direct sunlight, radiant heat, outside walls, behind doors, air discharge grills, stairwells, or outside doors

- away from steam or water pipes, warm air stacks, unconditioned areas (no heating and no cooling), or sources of electrical interference

Note: The TE-6800 Series sensor is shock and vibration resistant; however, be careful not to drop the unit or mount it where it could be exposed to excessive vibration.

The following ambient operating conditions apply:

- Temperature: 32 to 131°F (0 to 55°C)
- Humidity: 10 to 95% Relative Humidity (RH), noncondensing; 86°F (30°C) maximum dew point

To mount the sensor to the wall:

1. Use a 1/16 in. (1.5 mm) hex wrench or T-4000-119 hex-head adjustment tool to loosen the security screw on the top of the unit.
2. Insert a blade screwdriver into the slot next to the security screw location, and then carefully pry the top edge of the sensor assembly away from its mounting base and remove.

IMPORTANT: Do not remove the Printed Circuit Board (PCB). Removing the PCB voids the product warranty.

3. Pull out approximately 6 in. (152 mm) of cable from the wall, and insert the cable through the hole in the mounting base.
4. Align the mounting base on the wall, and use the base as a template to mark the location of the two mounting holes on the surface.

Note: Confirm that the mounting base is positioned with the proper edge up. The mounting base is positioned properly when the security screw is located on the top edge of the base.

5. Secure the mounting base to the wall using the appropriate mounting hardware (field furnished).
6. Set DIP switches as shown in Figure 1. See [Setup and Adjustments](#) and [Internal Wiring Diagrams](#) for additional information.

For models featuring a screw terminal block, wire the unit as illustrated in Figure 1.

7. Align the tabs on the bottom edge of the mounting base with the slots on the bottom edge of the sensor assembly, and rotate the assembly onto its mounting base.

Note: On models featuring a screw terminal block, be certain that the terminal block pins align with the holes in the terminal block.

8. Use a 1/16 in. (1.5 mm) hex wrench or T-4000-119 hex-head Adjustment Tool to tighten the security screw and fasten the network sensor assembly to the mounting base.

Wiring



CAUTION: Risk of Property Damage.
Do not apply power to the system before checking all wiring connections. Short circuited or improperly connected wires may result in permanent damage to the equipment.

IMPORTANT: Use copper conductors only. Make all wiring connections in accordance with local, national, and regional regulations.

Keep wires as short as possible to minimize sensor error. Each 250 ft (76 m) run of 18 AWG wire or 50 ft (15 m) of 24 AWG wire creates 1F° (0.56°C) error for a nickel sensor or 1.5°F (0.83°C) error for a platinum sensor due to wire resistance. To maintain less than 1F° (0.56°C) error for nickel or 1.5°F (0.83°C) error for platinum, hold the total resistance of all sensor wiring below 3 ohms. When wiring the TE-6800, do not run low voltage wiring in the same conduit as line voltage wiring or other conductors supplying highly inductive loads.

Internal Wiring Diagrams

Internal wiring diagrams are shown in Figure 1 . Terminal block designations are shown in Figure 2. The terminals are identified in Table 1. Make connections pairing the following wires:

- Sensor (Terminal 1 and Terminal 2)
- Setpoint (Terminal 3 and Terminal 4)
- Override Push Button Jumper (Terminal 2 and Terminal 6)

Shielding is not required. If used, follow the system controller’s recommendations for grounding the shield.

Note: The Manual Override PB does not respond when the DIP switch positions are all down.

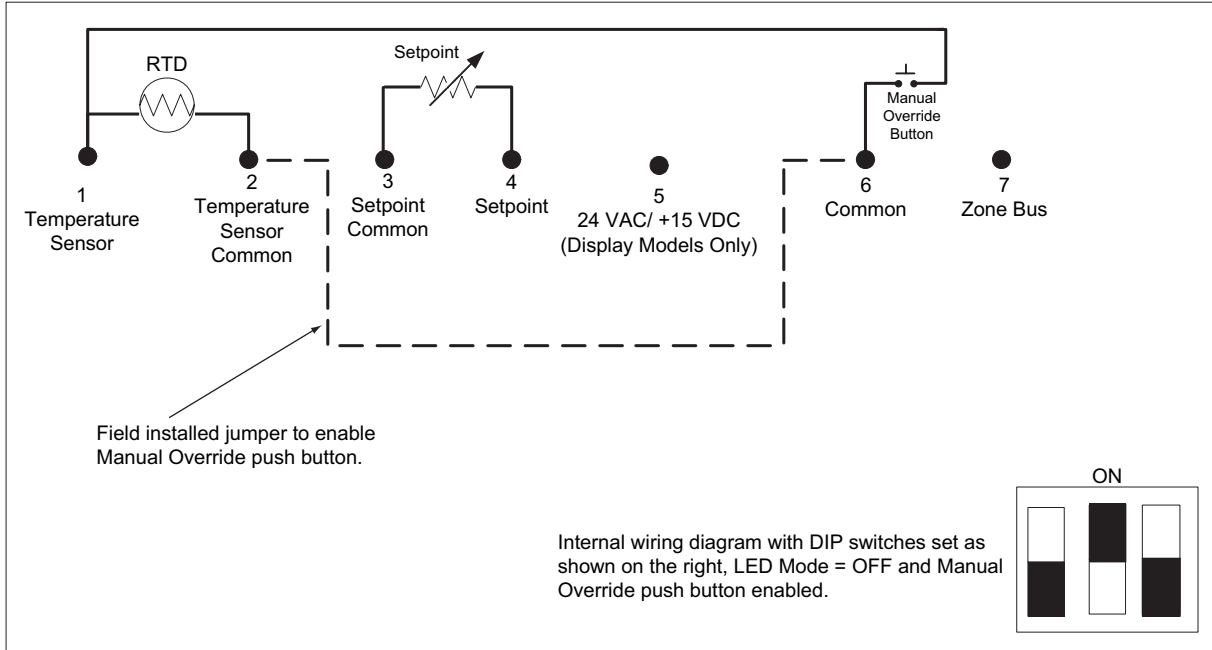

Figure 1: Terminal Block Wiring Designations (LED OFF Mode and Manual Override PB Enabled)

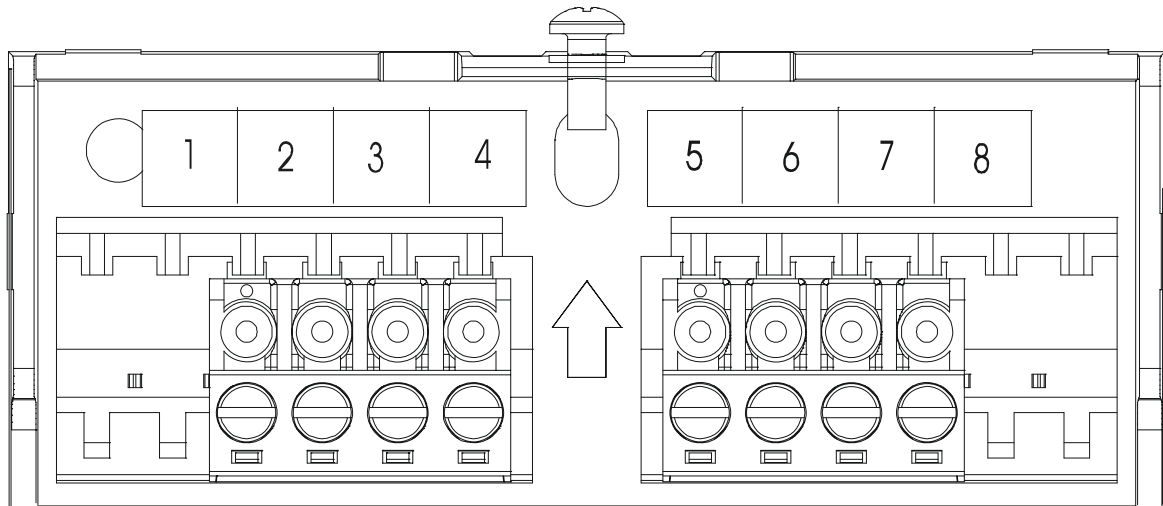

Figure 2: Terminal Block Location

Table 1: Terminal Block Wiring

Terminal	Signal Designation
1	Temperature Sensor
2	Temperature Sensor Common
3	Setpoint Common
4	Warmer/Cooler
5	N/A
6	Common (for Manual Override)
7	N/A
8	N/A

Setup and Adjustments

Controller Configuration Switch

A DIP switch configures the TE-6800 by enabling or disabling the manual override Push Button.



CAUTION: Risk of Property Damage.

Do not use switch settings other than those shown in Figure 1. Using other switch settings may cause incorrect controller operation or damage to the element, controller, and/or controlled equipment.

Warmer/Cooler Setpoint and No Setpoint Models

For the Warmer/Cooler Setpoint and No Setpoint models, the factory default is the **LED Mode: ON** described as follows. The switch positions enable/disable the following functions:

LED Mode: OFF Switch positions are
Sensor and PB Enabled down, up, and down.

Troubleshooting

TE-6800 Series Temperature Sensors are recommended for use only with York digital controllers. If the TE-6800 is not functioning properly, use the following procedure to identify the problem and determine a solution:

1. Check that the TE-6800 is mounted in a location indicative of the space temperature (for example, away from drafts or sunlight).
2. Check the wiring:
 - Verify that the wiring is correct.
3. Check the settings:
 - Check the override status (Temporary Occupancy mode vs. Unoccupied mode) at the System Manager or Zone Controller.
 - Check the setpoint settings.
4. Replace the TE-6800 if the troubleshooting suggestions fail to remedy the problem.

Repair Information

Do not field repair the TE-6800 temperature sensors. As with any electrical device, keep the air vents clean and free from dust or obstruction. If the TE-6800 temperature sensor fails to operate within its specifications, replace the unit. For a replacement sensor, contact the nearest Source 1 representative.

Technical Specifications

TE-6800 Series Temperature Sensors

Nickel Sensor	Temperature Sensor:	1,000 ohm thin-film nickel
	Temperature Coefficient:	Approximately 3 ohms per F° (5.4 ohms per C°)
	Reference Resistance:	1,000 ohms at 70°F (21°C)
	Accuracy:	±0.34°F at 70°F (±0.18°C at 21°C)
Setpoint Range	Single Adjustment:	Warmer/Cooler, -5 to 5°F
	Resistance:	Nominal 1.5k ohm
Sensor Response Time	One time constant:	10 minutes at 10 feet per minute airflow
Field Connections	Terminal Block:	Screw type terminals for 18 to 24 AWG wire
Manual Override	Integral momentary push button (DIP switch selectable)	
Ambient Operating Conditions	32 to 131°F (0 to 55°C) 10 to 95% RH, noncondensing; 86°F (30°C) maximum dew point	
Ambient Storage Conditions	-40 to 160°F (-40 to 71°C) 10 to 95% RH, noncondensing; 86°F (30°C) maximum dew point	
Mounting Style	Includes base and hardware for surface mounting.	
Materials	White thermoplastic	
Dimensions (H x W x D)	3.2 x 3.2 x 1.4 in. (81 x 81 x 36 mm)	
Shipping Weight	1 lb (0.5 kg)	

Subject to change without notice. Printed in U.S.A.
Copyright © 2008 by Johnson Controls, Inc. All rights reserved.

428544-YIM-A-0808
Ref: 24-10409-1

Johnson Controls Unitary Products
5005 York Drive
Norman, OK 73069