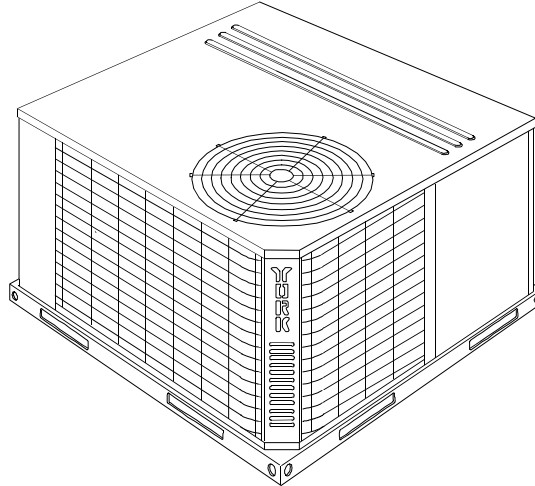

**MODELS B1HA018 THRU 060
1.5 THRU 5 TON
(10 SEER)****GENERAL**

YORK Model B1HA units are factory assembled heat pumps designed for outdoor installation on a rooftop or a slab. Field-installed electric heater accessories are available to provide supplemental electric heat combined with electric cooling and heating.

The units are completely assembled on rigid, removable base rails. All piping, refrigerant charge, and electrical wiring is factory installed and tested. The units require only electric power and duct connections at the point of installation.

The electric heaters have nickel-chrome resistance wire elements and utilize single point power connection.

INSPECTION

As soon as a unit is received, it should be inspected for possible damage during transit. If damage is evident, the extent of the damage should be noted on the carrier's freight bill. A separate request for inspection by the carrier's agent should be made in writing. Refer to Form 50.15-NM for additional information.

REFERENCE

Additional information on the design, installation, operation and service of this equipment is available in the following reference forms:

- 55.70-N1 -General Installation
- 55.70-N2 -Pre-start & Post-start Check List
- 511.26-N1.1V -Electric Heater Accessory

RENEWAL PARTS

- Refer to Replacement Parts Manual for complete listing of replacement parts on this equipment.

All forms referenced in this instruction may be ordered from:

Standard Register
Norman, OK 73069
Toll Free: Tel. 877-318-9675/Fax. 877-379-7920

Installer should pay particular attention to the words: *NOTE*, *CAUTION* and *WARNING*. Notes are intended to clarify or make the installation easier. Cautions are given to prevent equipment damage. Warnings are given to alert installer that personal injury and/or equipment damage may result if installation procedure is not handled properly.

CAUTION

THIS PRODUCT MUST BE INSTALLED IN STRICT COMPLIANCE WITH THE ENCLOSED INSTALLATION INSTRUCTIONS AND ANY APPLICABLE LOCAL, STATE, AND NATIONAL CODES INCLUDING, BUT NOT LIMITED TO, BUILDING, ELECTRICAL, AND MECHANICAL CODES.

WARNING

INCORRECT INSTALLATION MAY CREATE A CONDITION WHERE THE OPERATION OF THE PRODUCT COULD CAUSE PERSONAL INJURY OR PROPERTY DAMAGE.

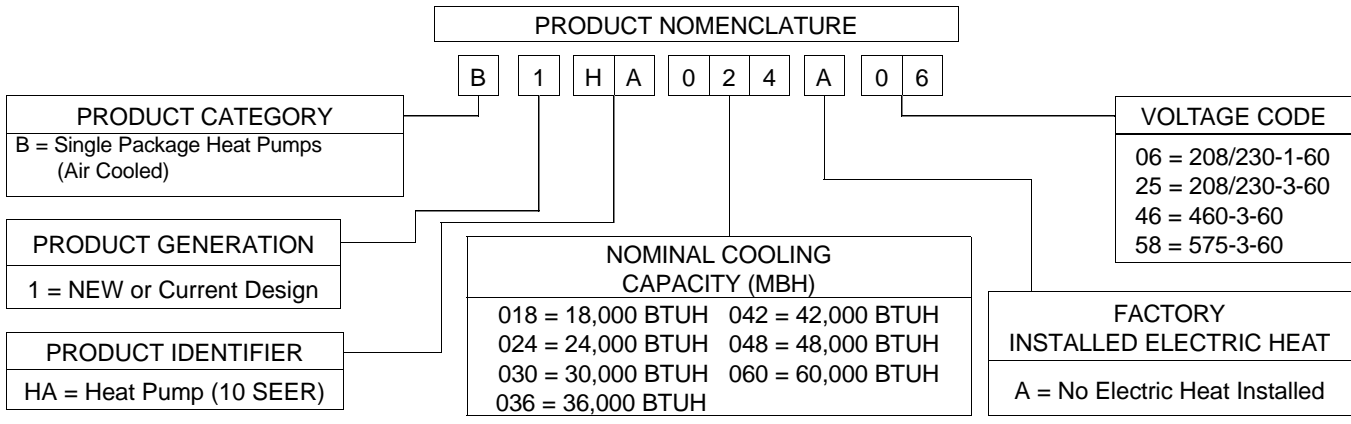

INSTALLATION

LIMITATIONS

These units must be installed in accordance with the following national and local safety codes.

1. National Electrical Code ANSI/NFPA No. 70 or Canadian Electrical Code Part 1, C22.1 (latest editions).
2. Local plumbing and waste water codes and other applicable local codes.

Refer to Table 1 for unit application data and to Table 4 for electric heat application data.

If components are to be added to a unit to meet local codes, they are to be installed at the dealer's and/or the customer's expense.

Size of unit for proposed installation should be based on heat loss/heat gain calculations made in accordance with industry recognized procedures identified by the Air Conditioning Contractors of America.

TABLE 1 - UNIT APPLICATION DATA

Voltage Variation Min. / Max. ¹	208/230V ³	187 / 253 ³
	460V	414 / 504
	575V	518 / 630
Wet Bulb Temperature (°F) of Air on Evaporator Coil, Min. / Max.	57 / 72	
Dry Bulb Temperature (°F) of Air on Condenser Coil, Min. ² / Max.	45 / 120	

¹ Rated in accordance with ARI Standard 110, utilization range "A".
² A low ambient accessory is available for operation down to 0°F
³ "T1" transformer primary tap must be moved from the 230 volt connection to the 208 volt connection for low voltage applications of 208 volt and below.

LOCATION

Use the following guidelines to select a suitable location for these units.

1. Unit is designed for outdoor installation only.
2. Condenser must have an unlimited supply of air. Where a choice of location is possible, position unit on either north or east side of building.
3. For ground level installation, a level pad or slab should be used. The thickness and size of the pad or slab used should meet local codes and unit weight. Do not tie the slab to the building foundation.
4. For roof top installation, be sure the structure will support the weight of the unit plus any field installed components.

- Unit must be installed on a level roof curb or appropriate angle iron frame providing adequate support under the compressor/condenser section.
5. Maintain level tolerance of unit to 1/8" maximum.

RIGGING OR HANDLING

Care must be exercised when moving the unit. Do not remove any packaging until the unit is near the place of installation. Rig unit with slings placed under the unit. Spreader bars of sufficient length should be used across the top of the unit.

BEFORE LIFTING A UNIT, MAKE SURE THAT ITS WEIGHT IS DISTRIBUTED EQUALLY ON THE CABLES SO THAT IT WILL LIFT EVENLY.

Units may also be moved or lifted with a fork-lift. Slotted openings in the skid are provided for this purpose. Forks must pass completely through the base.

Refer to Table 2 for unit weights and to Figure 1 for approximate center of gravity.

TABLE 2 - UNITS WEIGHTS

UNIT SIZE	SHIPPING WEIGHT (lbs.)	OPERATING WEIGHT (lbs.)	CORNER WEIGHTS (location, lbs.)			
			"A"	"B"	"C"	"D"
018	350	345	103	92	73	82
024	350	345	95	92	80	83
030	360	355	98	94	82	85
036	367	362	100	96	84	87
042	394	389	107	103	90	93
048	445	440	121	117	102	105
060	490	485	133	129	112	116

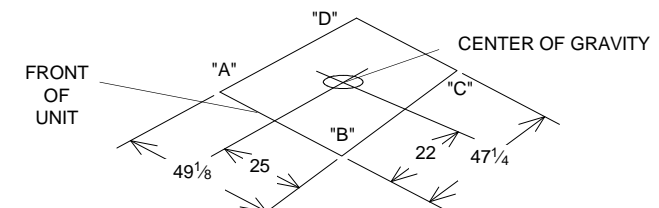

FIG. 1 - CENTER OF GRAVITY

CLEARANCES

All units require certain clearances for proper operation and service. Refer to Figure 3 for the clearances required for combustion, construction, servicing and proper unit operation.

WARNING: Do not permit overhanging structures or shrubs to obstruct the condenser air discharge outlet.

DUCT WORK

These units are adaptable to downflow use as well as rear supply and return air duct openings. To convert to downflow, use the following steps:

1. Remove the duct covers found in the bottom return and supply air duct openings. There are four (4) screws securing each duct cover (save these screws to use later).
2. Install the duct covers, removed in step one, to the rear supply and return air duct openings. Secure with the four (4) screws used in step one.
3. Seal duct covers with silicone caulk.

Downflow units must have an "L"-shaped supply duct without any outlets or registers located below the outlet of the unit.

Duct work should be designed and sized according to the methods of the Air Conditioning Contractors of America (ACCA), as set forth in their Manual D.

A closed return duct system shall be used. This shall not preclude use of economizers or ventilation air intake. Flexible joints may be used in the supply and return duct work to minimize the transmission of noise.

CAUTION: When fastening duct work to the side duct flanges on the unit, insert the screws through the duct flanges only. DO NOT insert the screws through the casing. Outdoor duct work must be insulated and waterproofed.

NOTE: Be sure to note supply and return openings.

Refer to Figure 3 for information concerning rear and bottom supply and return air duct openings.

FILTERS

Single phase units are shipped without a filter and is the responsibility of the installer to secure a filter **in the return air ductwork or install a Filter/Frame Kit (1FF0114)**.

A filter rack and high velocity filters are standard on three phase units.

Filters must always be used and must be kept clean. When filters become dirt laden, insufficient air will be delivered by the blower, decreasing your units efficiency and increasing operating costs and wear-and-tear on the unit and controls.

Filters should be checked monthly especially since this unit is used for both heating and cooling.

CONDENSATE DRAIN

A condensate trap is required to be installed in the condensate drain. The plumbing must conform to local codes. Use a sealing compound on male pipe threads. Install the condensate drain line (3/4" NPTF) to spill into an open drain.

CONTROL WIRING

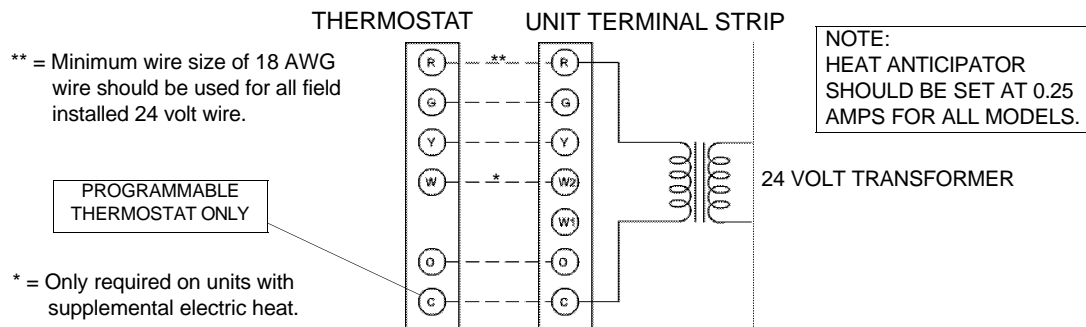

CAUTION: Label all wires prior to disconnection when servicing controls. Wiring errors can cause improper and dangerous operation. Verify proper operation after servicing.

POWER WIRING

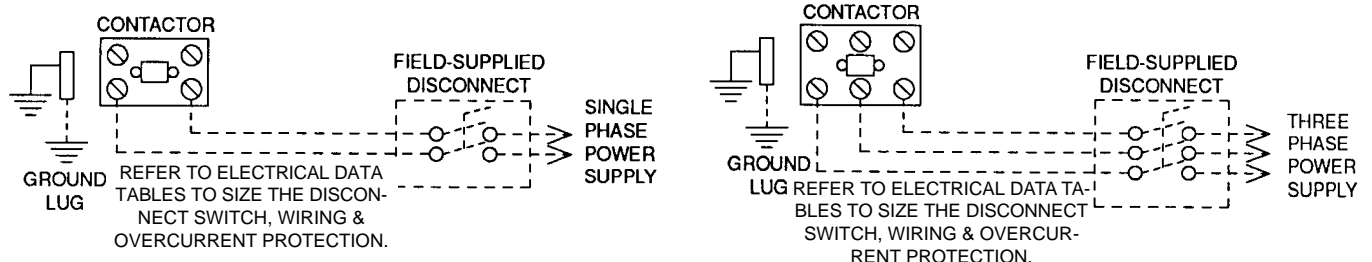

FIG. 2 - TYPICAL FIELD WIRING DIAGRAM

SERVICE ACCESS

Access to all serviceable components is provided by the following removable panels:

- Blower service access
- Electrical/Filter access
- Compressor service access

Refer to Figure 3 for location of these access panels and minimum clearances.

THERMOSTAT

The room thermostat should be located on an inside wall approximately 56" above the floor where it will not be subject to drafts, sun exposure or heat from electrical fixtures or appliances. Follow manufacturer's instructions enclosed with the thermostat for general installation procedure. Six color coded insulated wires (minimum #18 AWG) should be used to connect thermostat to unit. See Figure 2.

POWER AND CONTROL WIRING

Field wiring to the unit must conform to provisions of the current N.E.C. ANSI/NFPA No. 70 or C.E.C. and/or local ordinances. The unit must be electrically grounded in accordance with local codes or, in their absence, with the N.E.C./C.E.C. Voltage

tolerances which must be maintained at the compressor terminals during starting and running conditions are indicated on the unit Rating Plate and Table 3.

The wiring entering the cabinet must be provided with mechanical strain relief.

A fused disconnect switch should be field provided for the unit. If any of the wire supplied with the unit must be replaced, replacement wire must be of the type shown on the wiring diagram.

Electrical line must be sized properly to carry the load. Each unit must be wired with a separate branch circuit fed directly from the meter panel and properly fused.

Refer to Figure 2 for typical field wiring and to the appropriate unit wiring diagram for control circuit and power wiring information.

COMPRESSORS

Units are shipped with compressor mountings factory-adjusted and ready for operation.

CAUTION: Do Not loosen compressor mounting bolts.

TABLE 2 - PHYSICAL DATA

MODELS		BHA						
		018	024	030	036	042	048	060
INDOOR BLOWER	CENTRIFUGAL BLOWER (Dia. x Wd. in.)	9 X 6	10 X 8	10 X 8	10 x 8	11 X 10	11 X 10	11 X 10
	FAN MOTOR HP (Three Speed)	1/2	1/2	1/2	3/4	3/4	3/4	1
INDOOR COIL	ROWS DEEP	2	2	3	3	3	3	3
	FINS PER INCH	15	13	13	15	15	16	16
	FACE AREA (Sq. Ft.)	4.38	4.38	4.38	4.38	4.38	5.62	5.62
OUTDOOR FAN	PROPELLER DIA. (in.)	22	22	22	22	22	22	22
	FAN MOTOR HP	1/4	1/4	1/4	1/4	1/4	1/4	1/4
	NOM. CFM TOTAL	1,800	1,800	1,800	2,400	2,400	2,800	2,800
OUTDOOR COIL	ROWS DEEP	1	1	1	1	1	1	1
	FINS PER INCH	20	20	20	20	20	16	20
	FACE AREA (Sq. Ft.)	8.3	11.7	11.7	11.7	11.7	16.4	16.4
CHARGE	REFRIGERANT 22 (lbs./oz.)	4 / 12	5 / 12	7 / 8	5 / 5	5 / 5	9 / 0	10 / 0
FILTER	FACE AREA (Sq. Ft. / Qty. / Size)	4.28 / 2 / 14" x 22"						
COMPRESSOR	HERMETIC Type, (Qty. = 1)	Reciprocating	Reciprocating	Scroll	Scroll	Scroll	Scroll	Scroll

TABLE 3 - ADDITIONAL STATIC PRESSURE RESISTANCE

DISCRIPTION	RESISTANCE, IWG															
	CFM															
	500	600	700	800	900	1,000	1,100	1,200	1,300	1,400	1,500	1,600	1,700	1,800	1,900	2,000
Wet Indoor coil	0.01	0.01	0.01	0.02	0.02	0.03	0.03	0.04	0.04	0.04	0.04	0.04	0.05	0.05	0.06	0.07
Economizer	0.00	0.00	0.00	0.01	0.01	0.01	0.01	0.02	0.03	0.04	0.05	0.06	0.07	0.07	0.08	0.08
Filter/Frame Kit	0.01	0.02	0.02	0.02	0.02	0.02	0.03	0.03	0.03	0.03	0.04	0.05	0.05	0.06	0.06	0.07
Electric Heat	0.02	0.03	0.03	0.03	0.04	0.04	0.05	0.06	0.07	0.08	0.09	0.10	0.01	0.11	0.11	0.12

NOTE: 1. Deduct these resistance values from the available external static pressure shown in the respective Blower Performance Table.
 2. The pressure thru the economizer is greater for 100% outdoor air then for 100% return air. If the resistance of the return air duct system is less then 0.25 IWG, the unit will deliver less CFM during full economizer operation.

TABLE 4 - SIDE AND BOTTOM SUPPLY AIR BLOWER PERFORMANCE

230/460/575 volts

MODEL NO. BHA	MOTOR SPEED	EXTERNAL STATIC PRESSURE - IWG																					
		.10		.20		.30		.40		.50		.60		.70		.80		.90		1.00		1.10	
		CFM	WATTS	CFM	WATTS	CFM	WATTS	CFM	WATTS	CFM	WATTS	CFM	WATTS	CFM	WATTS	CFM	WATTS	CFM	WATTS	CFM	WATTS	CFM	WATTS
018	HI	-	-	-	-	-	-	-	-	-	-	668	401	652	386	-	-	-	-	-	-	-	-
	MED	-	-	-	-	-	-	-	-	654	233	541	209	-	-	-	-	-	-	-	-	-	-
	LOW	-	-	-	-	702	220	641	206	536	183	-	-	-	-	-	-	-	-	-	-	-	-
024	HI	-	-	-	-	-	-	-	-	-	-	-	-	-	-	987	507	873	493	760	480	-	-
	MED	-	-	-	-	-	-	-	-	935	338	867	322	800	304	733	286	867	268	-	-	-	-
	LOW	900	290	850	287	800	243	760	220	697	238	843	183	-	-	-	-	-	-	-	-	-	-
030	HI	-	-	-	-	-	-	-	-	-	-	1200	640	1100	620	987	507	873	493	760	480	-	-
	MED	1200	390	1134	397	1068	368	1002	367	936	339	897	322	800	304	-	-	-	-	-	-	-	-
	LOW	900	280	850	267	800	243	-	-	-	-	-	-	-	-	-	-	-	-	-	-	-	-
036	HI	-	-	-	-	-	-	-	-	1414	617	1317	688	1219	660	1116	533	1013	507	910	480	-	-
	MED	-	-	-	-	1472	647	1394	626	1297	495	1199	465	1102	435	985	397	-	-	-	-	-	-
	LOW	1462	526	1400	506	1337	486	1275	467	1167	440	1100	414	1012	387	-	-	-	-	-	-	-	-
042	HI	-	-	-	-	-	-	-	-	1697	740	1580	706	1463	672	1339	640	1216	608	1092	576	-	-
	MED	-	-	-	-	-	-	1673	830	1566	594	1439	558	1322	522	1182	476	-	-	-	-	-	-
	LOW	-	-	1680	607	1608	584	1630	660	1425	528	1320	496	1214	464	1050	420	-	-	-	-	-	-
048	HI	-	-	-	-	-	-	1947	882	1867	857	1786	832	1706	807	1637	782	1569	757	1500	732	-	-
	MED	1876	792	1829	772	1783	753	1736	733	1668	706	1599	680	1531	653	1434	622	1337	591	1240	560	-	-
	LOW	1544	620	1508	610	1472	600	1436	590	1375	573	1313	557	1252	540	-	-	-	-	-	-	-	-
060	HI	-	-	-	-	-	-	2499	1290	2391	1233	2283	1177	2175	1120	2067	1080	1958	1040	1850	1000	-	-
	MED	-	-	2454	1163	2387	1117	2320	1070	2229	1023	2137	977	2046	930	1950	887	1854	843	1758	800	-	-
	LOW	2242	1090	2201	1053	2161	1017	2120	980	2041	927	1962	873	1883	820	1797	787	1711	753	1625	720	-	-

NOTE: Above data includes allowances for a dry indoor coil and no filters. For additional pressure drops, refer to the "Additional Static Pressure Resistance" table.

208 volts

MODEL NO. BHA	MOTOR SPEED	EXTERNAL STATIC PRESSURE - IWG																					
		.10		.20		.30		.40		.50		.60		.70		.80		.90		1.00		1.10	
		CFM	WATTS	CFM	WATTS	CFM	WATTS	CFM	WATTS	CFM	WATTS	CFM	WATTS	CFM	WATTS	CFM	WATTS	CFM	WATTS	CFM	WATTS	CFM	WATTS
018	HI	-	-	-	-	-	-	-	-	689	374	593	361	497	347	-	-	-	-	-	-	-	-
	MED	-	-	-	-	-	-	690	231	659	210	487	188	-	-	-	-	-	-	-	-	-	-
	LOW	741	226	686	212	632	198	577	185	453	165	-	-	-	-	-	-	-	-	-	-	-	-
024	HI	-	-	-	-	-	-	-	-	-	-	-	-	990	468	888	456	786	444	684	432	-	-
	MED	-	-	-	-	961	351	902	321	841	305	751	290	720	274	660	257	-	-	-	-	-	-
	LOW	810	261	765	240	720	219	675	198	627	215	-	-	-	-	-	-	-	-	-	-	-	-
030	HI	-	-	-	-	-	-	-	-	1171	604	1080	486	980	468	888	456	786	444	-	-	-	-
	MED	1080	351	1021	341	961	331	902	321	841	306	781	280	-	-	-	-	-	-	-	-	-	-
	LOW	810	261	766	240	-	-	-	-	-	-	-	-	-	-	-	-	-	-	-	-	-	-
036	HI	-	-	-	-	1440	608	1381	581	1273	656	1185	530	1097	604	1004	480	912	456	-	-	-	-
	MED	1465	631	1395	512	1325	492	1255	473	1167	446	1079	419	952	392	-	-	-	-	-	-	-	-
	LOW	1316	473	1260	455	1204	438	1148	420	1069	396	990	372	911	348	-	-	-	-	-	-	-	-
042	HI	-	-	-	-	1728	725	1633	697	1527	666	1422	636	1317	606	1205	676	1094	547	-	-	-	-
	MED	-	-	1674	614	1590	590	1506	567	1400	636	1296	602	1190	470	1063	428	-	-	-	-	-	-
	LOW	1679	867	1612	646	1449	526	1377	504	1282	476	1188	447	1093	418	-	-	-	-	-	-	-	-
048	HI	-	-	1982	870	1939	850	1897	830	1813	800	1728	770	1644	740	1559	707	1474	673	1389	640	-	-
	MED	1694	690	1662	673	1629	657	1597	640	1542	623	1486	607	1431	590	1336	563	1240	537	-	-	-	-
	LOW	1385	520	1349	510	1312	500	1276	490	1235	480	-	-	-	-	-	-	-	-	-	-	-	-
060	HI	-	-	-	-	2450	1213	2366	1165	2282	1117	2198	1068	2114	1020	1989	993	1864	967	1739	940	-	-
	MED	2339	1170	2275	1118	2211	1067	2147	1015	2083	963	2019	912	1955	860	1854	824	1753	788	1652	752	-	-
	LOW	1929	940	1877	903	1824	867	1772	830	1720	793	1667	757	1615	720	1586	706	1557	691	1528	677	-	-

NOTE: Above data includes allowances for a dry indoor coil and no filters. For additional pressure drops, refer to the "Additional Static Pressure Resistance" table.

ELECTRIC HEAT CORRECTION FACTORS	NOMINAL VOLTAGE	VOLTAGE	KW CAP. MULTIPLIER
	240	208	.75
	480	230	.92
	600	460	.92
	600	575	.92

TABLE 5 - ELECTRICAL DATA (HEAT PUMP / ELECTRIC HEAT)

MODEL	BHA	POWER SUPPLY	COMPRESSOR		OUTDOOR FAN MOTOR FLA	SUPPLY AIR BLOWER MOTOR, FLA	ELECTRIC HEAT ACCESSORY				MINIMUM CIRCUIT AMPACITY	MAX. FUSE SIZE, ① AMPS	MAX. HACR ② BREAKER SIZE
			RLA	LRA			MODEL NO.	STAGE	KW	TOTAL AMPS			
018	208/230-1-60	9.0	48.0	1.1	2.6	2NH04500506	1	3.8/5.0 *	18.1/20.8	37.5/41.0	40/45	40/45	
						2NH04500706	2	5.6/7.5 *	27.1/31.3	48.8/54.0	50/60	50/60	
024	208/230-1-60	11.2	60.0	1.1	2.6	2NH04500506	1	3.8/5.0 *	18.1/20.8	40.7/44.2	45/50	45/50	
						2NH04500706	2	5.6/7.5 *	27.1/31.3	52.0/57.2	60/60	60/60	
030	208/230-1-60	14.7	73.0	1.1	2.6	2NH04500506	1	3.8/5.0 *	18.1/20.8	44.7/48.2	50/50	50/50	
						2NH04500706	2	5.6/7.5 *	27.3/31.3	56.0/61.2	60/70	60/70	
036	208/230-1-60	17.3	94.0	1.1	3.5	2NH04501006	2	7.5/10.0 *	36.1/41.7	67.3/74.2	70/80	70/80	
						2NH04501506	2	11.3/15.0 *	54.2/62.5	93.9/104.4	100/110	100/110	
042	208/230-1-60	20.5	120.0	1.1	3.5	2NH04500506	1	3.8/5.0 *	18.1/20.8	52.8/56.3	60/70	60/70	
						2NH04500706	2	5.6/7.5 *	27.1/31.3	64.1/69.3	70/80	70/80	
048	208/230-1-60	24.4	140.0	1.5	4.0	2NH04501006	2	7.5/10.0 *	36.1/41.7	81.1/88.1	90/100	90/100	
						2NH04502006	2	15.0/20.0 *	72.2/83.3	126.3/140.2	150/150	150/150	
060	208/230-1-60	28.9	165.0	1.5	7.0	2NH04501006	2	7.5/10.0 *	36.1/41.7	89.8/96.7	100/110	100/110	
						2NH04501506	2	11.3/15.0 *	54.2/62.5	112.3/122.8	125/125	125/125	
036	208/230-3-60	10.9	78.0	1.1	3.5	2NH04501025	1	7.5/10.0 *	20.8/24.1	44.3/48.3	45/50	45/50	
						2NH04501525	1	11.3/15.0 *	31.3/36.1	57.3/63.3	60/70	60/70	
042	208/230-3-60	14.1	110.0	1.1	3.5	2NH04501025	1	7.5/10.0 *	20.8/24.1	48.3/57.3	50/60	50/60	
						2NH04501525	1	11.3/15.0 *	31.3/36.1	61.3/67.3	70/70	70/70	
048	208/230-3-60	14.1	105.0	1.5	4.0	2NH04501025	1	7.5/10.0 *	20.8/24.1	49.2/53.2	50/60	50/60	
						2NH04501525	1	11.3/15.0 *	31.3/36.1	62.2/68.2	70/70	70/70	
060	208/230-3-60	16.0	125.0	1.5	7.0	2NH04502025	2	15.0/20.0 *	41.7/48.1	75.3/83.3	80/90	80/90	
						2NH04502525	2	18.8/25.0 *	52.1/60.1	88.3/98.3	90/100	90/100	
036	460-3-60	5.8	40.0	0.6	1.8	2NH04501046	1	10.0 **	12.8	24.6	25	25	
						2NH04501546	1	15.0 **	18.0	32.2	35	35	
042	460-3-60	7.1	54.0	0.6	1.8	2NH04501046	1	10.0 **	12.0	26.2	30	30	
						2NH04501546	1	15.0 **	18.0	33.8	35	35	
048	460-3-60	7.1	55.0	0.8	2.0	2NH04501046	1	10.0 **	12.0	26.7	30	30	
						2NH04501546	1	15.0 **	18.0	34.2	35	35	
060	460-3-60	8.0	67.0	0.8	3.5	2NH04502046	2	20.0 **	24.1	41.7	45	45	
						2NH04502546	2	25.0 **	30.1	49.3	50	50	
036	460-3-60	5.8	40.0	0.6	1.8	2NH04501046	1	10.0 **	12.0	29.4	30	30	
						2NH04501546	1	15.0 **	18.0	36.9	40	40	
042	460-3-60	7.1	54.0	0.6	1.8	2NH04501046	1	10.0 **	12.0	29.4	30	30	
						2NH04501546	1	15.0 **	18.0	36.9	40	40	
048	460-3-60	7.1	55.0	0.8	2.0	2NH04502046	2	20.0 **	24.1	44.4	45	45	
						2NH04502546	2	25.0 **	30.1	51.9	60	60	

① = Dual element, time delay type.
 ② = Standard circuit breakers may be used in Canada and on applications over 60 amps where the heaters are separately fused.

* = KW listed is for 240 volts, use table at top of page for 208 or 230 volts.
 ** = KW listed is for 480 volts, use table at top of page for 460 volts.
 *** = KW listed is for 600 volts, use table at top of page for 575 volts.

TABLE 5 - ELECTRICAL DATA (HEAT PUMP / ELECTRIC HEAT) (Continued)

MODEL	BHA	POWER SUPPLY	COMPRESSOR		OUTDOOR FAN MOTOR FLA	SUPPLY AIR BLOWER MOTOR, FLA	ELECTRIC HEAT ACCESSORY				MINIMUM CIRCUIT AMPACITY	MAX. FUSE SIZE, ① AMPS	MAX. HACR ② BREAKER SIZE
			RLA	LRA			MODEL NO.	STAGE	KW	TOTAL AMPS			
036	575-3-60	4.5	32.0	0.4	1.5	2NH04501058	1	10.0 ***	9.6	19.6	20	20	
						2NH04501558	1	15.0 ***	14.4	25.6	30	30	
042	575-3-60	5.8	44.0	0.4	1.5	2NH04501058	1	10.0 ***	9.6	21.1	25	25	
						2NH04501558	1	15.0 ***	14.4	27.2	30	30	
048	575-3-60	5.6	44.0	0.6	1.6	2NH04501058	1	10.0 ***	9.6	21.3	25	25	
						2NH04501558	1	15.0 ***	14.4	27.3	30	30	
						2NH04502058	2	20.0 ***	19.2	33.3	35	35	
						2NH04502558	2	25.0 ***	24.1	39.3	40	40	
060	575-3-60	6.4	50.0	0.6	2.8	2NH04501058	1	10.0 ***	9.6	23.4	25	25	
						2NH04501558	1	15.0 ***	14.4	29.5	30	30	
						2NH04502058	2	20.0 ***	19.2	35.5	40	40	
						2NH04502558	2	25.0 ***	24.1	41.5	45	45	

① = Dual element, time delay type.

② = Standard circuit breakers may be used in Canada and on applications over 60 amps where the heaters are separately fused.

* = KW listed is for 240 volts, use table at top of page for 208 or 230 volts.

** = KW listed is for 480 volts, use table at top of page for 460 volts.

*** = KW listed is for 600 volts, use table at top of page for 575 volts.

TABLE 6 - ELECTRICAL DATA (BASIC UNIT)

MODEL BHA	POWER SUPPLY	VOLTAGE LIMITATIONS ①		COMPRESSOR		OUTDOOR FAN MOTOR, FLA	SUPPLY AIR BLOWER MOTOR, FLA	MINIMUM CIRCUIT AMPACITY	MAX. FUSE SIZE, AMPS ②	MAX. HACR BREAKER SIZE, AMPS	UNIT POWER FACTOR	TRANSFORMER SIZE (VA)
		MIN.	MAX.	RLA	LRA							
018	208/230-1-60	187	253	9.0	48.0	1.1	2.6	14.9	20	20	.96	40
024	208/230-1-60	187	253	11.2	60.0	1.1	2.6	17.7	25	25	.96	40
030	208/230-1-60	187	253	12.0	73.0	1.1	2.6	18.7	25	25	.96	40
036	208/230-1-60	187	253	17.3	94.0	1.1	3.5	26.2	35	35	.96	40
042	208/230-1-60	187	253	20.5	120.0	1.1	3.5	30.2	40	40	.96	40
048	208/230-1-60	187	253	24.4	140.0	1.5	4.0	36.0	50	50	.96	40
060	208/230-1-60	187	253	28.9	165.0	1.5	7.0	44.6	60	60	.96	40
036	208/230-3-60	187	253	10.9	78.0	1.1	3.5	18.2	25	25	.96	75
042	208/230-3-60	187	253	14.1	110.0	1.1	3.5	22.2	30	30	.96	75
048	208/230-3-60	187	253	14.1	105.0	1.5	4.0	23.1	30	30	.96	75
060	208/230-3-60	187	253	16.0	125.0	1.5	7.0	28.5	40	40	.96	75
036	460-3-60	414	504	5.8	40.0	0.6	1.8	9.6	15	15	.96	75
042	460-3-60	414	504	7.1	54.0	0.6	1.8	11.2	15	15	.96	75
048	460-3-60	414	504	7.1	55.0	0.8	2.0	11.7	15	15	.96	75
060	460-3-60	414	504	8.0	67.0	0.8	3.5	14.3	20	20	.96	75
036	575-3-60	518	630	4.5	32.0	0.4	1.5	7.6	15	15	.96	75
042	575-3-60	518	630	5.8	44.0	0.4	1.5	9.1	15	15	.96	75
048	575-3-60	518	630	5.6	44.0	0.6	1.6	9.3	15	15	.96	75
060	575-3-60	518	630	6.4	50.0	0.6	2.8	11.4	15	15	.96	75

① = Rated in accordance with ARI Standard 110, utilization range "A".

② = Dual element, time delay type.

TABLE 7 - COOLING SUPERHEAT AT COMPRESSOR SUCTION, AIRFLOW = 600 CFM (B1HA018)

OUTDOOR TEMPERATURE, °F	INDOOR WB TEMPERATURE, °F										
	55	57	59	61	63	65	67	69	71	73	75
65	9.2	14.5	19.7	25.0	30.2	35.5	40.8	40.3	39.7	39.2	38.7
70	9.6	14.2	18.8	23.4	28.0	32.5	37.1	37.3	37.5	37.7	37.9
75	10.1	14.0	17.9	21.8	25.7	29.5	33.4	34.3	35.2	36.1	37.0
80	10.5	13.7	17.0	20.2	23.4	26.6	29.8	31.4	33.0	34.6	36.2
85	11.0	13.5	16.0	18.5	21.1	23.6	26.1	28.4	30.7	33.0	35.4
90	11.4	13.3	15.1	16.9	18.8	20.6	22.4	25.5	28.5	31.5	34.5
95	11.9	13.0	14.2	15.3	16.5	17.6	18.8	22.5	26.2	30.0	33.7
100	9.0	10.3	11.7	13.1	14.4	15.8	17.1	20.1	23.0	26.0	28.9
105	6.0	7.6	9.2	10.8	12.4	14.0	15.5	17.7	19.8	22.0	24.1
110	-	-	6.7	8.5	10.3	12.1	13.9	15.3	16.6	18.0	19.3
115	-	-	-	6.3	8.3	10.3	12.3	12.9	13.4	14.0	14.5

TABLE 8 - HEATING SUPERHEAT AT COMPRESSOR SUCTION, AIRFLOW = 600 CFM (B1HA018)

INDOOR DB TEMPERATURE, °F	OUTDOOR TEMPERATURE, °F							
	-10	0	10	20	30	40	50	60
55	9.7	10.2	10.9	12.1	14.2	17.6	23.3	32.8
70	-	-	-	3.0	5.1	8.5	14.2	23.7
80	-	-	-	-	-	4.1	9.8	19.3

TABLE 9 - COOLING SUPERHEAT AT COMPRESSOR SUCTION, AIRFLOW = 800 CFM (B1HA024)

OUTDOOR TEMPERATURE, °F	INDOOR WB TEMPERATURE, °F										
	55	57	59	61	63	65	67	69	71	73	75
65	17.0	18.2	19.4	20.5	21.7	22.8	24.0	27.0	30.0	33.0	36.0
70	14.3	15.5	16.7	17.8	19.0	20.1	21.3	24.6	27.9	31.1	34.4
75	11.6	12.8	13.9	15.1	16.3	17.4	18.6	22.2	25.7	29.3	32.9
80	8.9	10.1	11.2	12.4	13.6	14.7	15.9	19.7	23.6	27.5	31.4
85	6.2	7.4	8.5	9.7	10.9	12.0	13.2	17.3	21.5	25.7	29.9
90	-	-	5.8	7.0	8.2	9.3	10.5	14.5	19.4	23.9	28.3
95	-	-	-	-	5.5	6.6	7.8	12.5	17.3	22.1	26.8
100	-	-	-	-	-	5.4	6.3	10.4	14.6	18.7	22.9
105	-	-	-	-	-	-	-	8.3	11.8	15.4	19.0
110	-	-	-	-	-	-	-	6.2	9.1	12.1	15.0
115	-	-	-	-	-	-	-	-	6.4	8.8	11.1

TABLE 10 - HEATING SUPERHEAT AT COMPRESSOR SUCTION, AIRFLOW = 800 CFM (B1HA024)

INDOOR DB TEMPERATURE, °F	HEATING SUPERHEAT AT COMPRESSOR SUCTION, °F							
	-10	0	10	20	30	40	50	60
55	12.6	13.0	13.5	14.2	15.4	17.2	19.9	24.2
70	-	-	-	-	3.3	5.1	7.9	12.1
80	-	-	-	-	-	-	4.9	9.1

TABLE 11 - COOLING SUPERHEAT AT COMPRESSOR SUCTION, AIRFLOW = 1,000 CFM (B1HA030)

OUTDOOR TEMPERATURE, °F	INDOOR WB TEMPERATURE, °F										
	55	57	59	61	63	65	67	69	71	73	75
65	17.0	20.0	22.9	25.9	28.9	31.8	34.8	39.0	43.1	47.3	51.5
70	14.3	16.9	19.5	22.2	24.8	27.5	30.1	34.2	38.2	42.3	46.4
75	11.5	13.9	16.2	18.5	20.8	23.1	25.4	29.4	33.4	37.3	41.3
80	8.8	10.8	12.8	14.8	16.7	18.7	20.7	24.6	28.5	32.3	36.2
85	6.1	7.7	9.4	11.0	12.7	14.4	16.0	19.8	23.6	27.4	31.1
90	-	-	6.0	7.3	8.7	10.0	11.3	15.0	18.7	22.4	26.1
95	-	-	-	-	-	5.6	6.6	10.2	13.8	17.4	21.0
100	-	-	-	-	-	-	5.2	7.9	10.7	13.4	16.2
105	-	-	-	-	-	-	-	5.6	7.6	9.5	11.4
110	-	-	-	-	-	-	-	-	-	5.6	6.7
115	-	-	-	-	-	-	-	-	-	-	-

TABLE 12 - HEATING SUPERHEAT AT COMPRESSOR SUCTION, AIRFLOW = 1,000 CFM (B1HA030)

INDOOR DB TEMPERATURE, °F	OUTDOOR TEMPERATURE, °F							
	-10	0	10	20	30	40	50	60
55	15.3	15.6	16.0	16.8	17.9	19.6	22.2	26.2
70	-	-	-	-	3.2	4.9	7.5	11.5
80	-	-	-	-	-	-	4.5	8.5

TABLE 13 - COOLING SUPERHEAT AT COMPRESSOR SUCTION, AIRFLOW = 1,200 CFM (B1HA036)

OUTDOOR TEMPERATURE, °F	INDOOR WB TEMPERATURE, °F										
	55	57	59	61	63	65	67	69	71	73	75
65	12.8	16.1	19.3	22.5	25.8	29.0	32.2	35.0	37.7	40.4	43.1
70	11.4	14.3	17.2	20.1	22.9	25.8	28.7	31.6	34.4	37.3	40.1
75	9.9	12.5	15.0	17.6	20.1	22.7	25.2	28.2	31.1	34.1	37.1
80	8.5	10.7	12.9	15.1	17.3	19.5	21.7	24.8	27.9	31.0	34.0
85	7.0	8.9	10.8	12.6	14.5	16.3	18.2	21.4	24.6	27.8	31.0
90	5.6	7.1	8.6	10.1	11.7	13.2	14.7	18.0	21.3	24.7	28.0
95	-	5.3	6.5	7.7	8.8	10.0	11.2	14.6	18.1	21.5	25.0
100	-	-	5.1	6.0	6.9	7.8	8.7	11.7	14.7	17.7	20.7
105	-	-	-	-	-	5.6	6.2	8.7	11.3	13.9	16.4
110	-	-	-	-	-	-	-	5.8	7.9	10.0	12.2
115	-	-	-	-	-	-	-	-	-	6.2	7.9

TABLE 14 - HEATING SUPERHEAT AT COMPRESSOR SUCTION, AIRFLOW = 1,200 CFM (B1HA036)

INDOOR DB TEMPERATURE, °F	HEATING SUPERHEAT AT COMPRESSOR SUCTION, °F								
	-10	0	10	20	30	40	50	60	
55	9.7	10.1	10.7	11.8	13.7	17.0	22.6	32.2	
70	-	-	-	-	4.6	7.8	13.4	23.0	
80	-	-	-	-	-	-	7.3	16.9	

TABLE 15 - COOLING SUPERHEAT AT COMPRESSOR SUCTION, AIRFLOW = 1,400 CFM (B1HA042)

OUTDOOR TEMPERATURE, °F	INDOOR WB TEMPERATURE, °F										
	55	57	59	61	63	65	67	69	71	73	75
65	34.0	34.2	34.4	34.6	34.8	35.0	35.2	36.2	37.3	38.4	39.4
70	31.1	31.5	31.9	32.2	32.6	33.0	33.4	34.8	36.3	37.7	39.2
75	28.3	28.8	29.4	29.9	30.5	31.0	31.6	33.4	35.3	37.1	39.0
80	25.4	26.1	26.9	27.6	28.3	29.1	29.8	32.0	34.3	36.5	38.7
85	22.6	23.5	24.4	25.3	26.2	27.1	28.0	30.6	33.2	35.9	38.5
90	19.7	20.8	21.9	23.0	24.0	25.1	26.2	29.2	32.2	35.2	38.3
95	16.9	18.1	19.4	20.6	21.9	23.2	24.4	27.8	31.2	34.6	38.0
100	14.5	15.6	16.6	17.7	18.7	19.7	20.8	24.4	27.9	31.5	35.1
105	12.2	13.1	13.9	14.7	15.5	16.3	17.1	20.9	24.6	28.4	32.1
110	9.9	10.5	11.1	11.7	12.3	12.9	13.5	17.4	21.3	25.3	29.2
115	7.6	8.0	8.4	8.8	9.1	9.5	9.9	14.0	18.1	22.1	26.2

TABLE 16 - HEATING SUPERHEAT AT COMPRESSOR SUCTION, AIRFLOW = 1,400 CFM (B1HA042)

INDOOR DB TEMPERATURE, °F	OUTDOOR TEMPERATURE, °F								
	-10	0	10	20	30	40	50	60	
55	5.1	5.5	6.2	7.4	9.6	13.5	20.3	32.4	
70	-	-	-	-	5.0	8.9	15.7	27.8	
80	-	-	-	-	-	5.4	12.2	24.3	

TABLE 17 - COOLING SUPERHEAT AT COMPRESSOR SUCTION, AIRFLOW = 1,600 CFM (B1HA048)

OUTDOOR TEMPERATURE, °F	INDOOR WB TEMPERATURE, °F										
	55	57	59	61	63	65	67	69	71	73	75
65	11.4	12.4	13.5	14.6	15.7	16.8	17.9	19.3	20.7	22.1	23.5
70	10.3	11.2	12.2	13.1	14.0	14.9	15.9	17.4	18.9	20.4	21.9
75	9.3	10.0	10.8	11.6	12.3	13.1	13.9	15.4	17.0	18.6	20.2
80	8.2	8.8	9.4	10.0	10.6	11.2	11.8	13.5	15.2	16.9	18.5
85	7.2	7.7	8.1	8.5	9.0	9.4	9.8	11.6	13.4	15.1	16.9
90	6.5	7.0	7.4	7.9	8.3	8.8	9.2	10.6	12.0	13.4	14.8
95	5.9	6.3	6.8	7.2	7.7	8.1	8.6	9.6	10.6	11.6	12.6
100	-	5.5	6.1	6.6	7.2	7.8	8.4	9.3	10.3	11.3	12.3
105	-	-	5.4	6.1	6.8	7.5	8.2	9.1	10.1	11.0	11.9
110	-	-	-	5.5	6.3	7.2	8.0	8.9	9.8	10.7	11.6
115	-	-	-	-	5.9	6.9	7.8	8.7	9.5	10.4	11.2

TABLE 18 - HEATING SUPERHEAT AT COMPRESSOR SUCTION, AIRFLOW = 1,600 CFM (B1HA048)

INDOOR DB TEMPERATURE, °F	HEATING SUPERHEAT AT COMPRESSOR SUCTION, °F							
	-10	0	10	20	30	40	50	60
55	8.3	8.4	8.6	9.0	10.1	12.4	17.4	28.6
70	-	-	-	-	-	4.2	9.2	20.4
80	-	-	-	-	-	-	5.7	16.9

TABLE 19 - COOLING SUPERHEAT AT COMPRESSOR SUCTION, AIRFLOW = 2,000 CFM (B1HA060)

OUTDOOR TEMPERATURE, °F	INDOOR WB TEMPERATURE, °F										
	55	57	59	61	63	65	67	69	71	73	75
65	26.7	27.6	28.5	29.4	30.3	31.2	32.1	33.0	33.9	34.8	35.7
70	21.9	23.0	24.1	25.2	26.3	27.4	28.5	30.0	31.4	32.8	34.3
75	17.0	18.3	19.7	21.0	22.3	23.7	25.0	27.0	28.9	30.9	32.9
80	12.2	13.7	15.3	16.8	18.4	19.9	21.5	24.0	26.5	29.0	31.4
85	7.3	9.1	10.8	12.6	14.4	16.2	17.9	20.9	24.0	27.0	30.0
90	7.2	8.3	9.4	10.6	11.7	12.8	13.9	17.3	20.6	23.9	27.2
95	7.0	7.5	8.0	8.5	9.0	9.5	9.9	13.6	17.2	20.8	24.4
100	7.2	7.6	8.0	8.3	8.7	9.1	9.5	12.4	15.3	18.2	21.1
105	7.4	7.7	7.9	8.2	8.5	8.7	9.0	11.2	13.4	15.6	17.8
110	7.6	7.8	7.9	8.1	8.2	8.4	8.5	10.0	11.5	13.0	14.4
115	7.8	7.8	7.9	7.9	8.0	8.0	8.1	8.8	9.6	10.3	11.1

TABLE 20 - HEATING SUPERHEAT AT COMPRESSOR SUCTION, AIRFLOW = 2,000 CFM (B1HA060)

INDOOR DB TEMPERATURE, °F	OUTDOOR TEMPERATURE, °F							
	-10	0	10	20	30	40	50	60
55	5.5	5.7	6.2	6.8	8.0	9.9	13.1	18.6
70	-	-	-	-	-	4.8	8.0	13.4
80	-	-	-	-	-	-	5.6	11.0

SEQUENCE OF OPERATION

Anti-short Cycle Timer

This unit has an anti-short cycle timer built in to the defrost control. This timer will not permit the compressor to start within five minutes after the completion of the last cycle or power interruption. To bypass the anti-short cycle feature, short the "TEST" pins together for 2 seconds.

The following sequences of operation are based on using a standard single-stage heat pump thermostat.

Cooling Operation

WITH POWER TO UNIT AND THERMOSTAT IN COOLING MODE.

1. If the fan switch on the thermostat is in the "ON" position, the 24 volts at "G" will energize the "K1" relay on the fan control board, close the "K1" relay contacts, and energize the indoor blower motor. If the fan switch on the thermostat is in the "AUTO" position, the blower will operate only when there is a call for cooling by the thermostat.
2. On a call for cooling, the thermostat will send 24 volts to "Y" and "O" on the fan control board. After the anti-short cycle period is complete, the 24 volt signal will energize contactor "M1", and the reversing valve solenoid. Power will be supplied to the compressor and outdoor fan motor, and the reversing valve will switch to the cooling position. If the fan switch on the thermostat is on the "AUTO" position, the fan control will energize the indoor blower.
3. When the demand for cooling has been satisfied, the 24 volt "Y" signal is removed and the "M1" contactor will be de-energized. If the fan switch on the thermostat is in the "ON" position, the indoor blower will continue to run. If the fan switch is in the "AUTO" position, the "K1" relay will open and de-energize the indoor blower motor after a 60 second delay.

Heating Operation

WITH POWER TO UNIT AND THERMOSTAT IN HEATING MODE.

1. If the fan switch on the thermostat is in the "ON" position, the 24 volts at "G" will energize the "K1" relay on the fan control board, close the "K1" relay contacts, and energize the indoor blower motor. If the fan switch on the thermostat is in the "AUTO" position, the blower will operate only when there is a call for heating by the thermostat.
2. On a call for heating, the thermostat will send 24 volts to "Y" on the fan control board. After the anti-short cycle period is complete, the 24 volts signal will energize contactor coil "M1" and power will be supplied to the compressor and outdoor fan motor. The reversing valve will remain in the heating position. If the fan switch on the thermostat is in the "AUTO" position, the fan control will energize the indoor blower.
3. For units equipped with supplementary electric heat, if the heat pump cannot meet the demand, the thermostat "W" will send 24 volts to "W2" on the fan control board. This signal will also be sent through the defrost control terminals "W" and "W1/66" and back to the fan control "W1". This 24 volt signal will energize all stages of electric heat.
4. When the heating demand is satisfied, the electric heat will be de-energized when the 24 volt "W" signal is removed, and the "M1" contactor will be de-energized when the 24 volt "Y" signal is removed. If the fan switch on the thermostat

is in the "ON" position, the indoor blower will continue to run. If the fan switch is in the "AUTO" position, the "K1" relay will open and de-energize the indoor blower motor after the appropriate time delay.

Please refer to Tables 7 and 8 for more information.

Defrost Operation

The minimum time between defrosts can be field selected at 30, 60 or 90 minutes. The default time is 90 minutes if the jumper is not installed.

Defrost will initiate when the defrost sensor, located on the outdoor coil, senses a temperature below 31°F and when the time since the last defrost is greater than the selected time on the defrost control. The defrost cycle terminates when either the defrost sensor reaches 55°F or the unit has been in defrost mode for 10 minutes. If the room thermostat opens during defrost, the unit will resume operation in defrost when the thermostat re-closes.

During the defrost mode, the defrost control will provide a 24 volt signal from terminal "W1/66" to the fan control terminal "W1". This signal will energize electric heat stage 1, if the unit is so equipped.

For trouble shooting purposes, the defrost cycle can be manually initiated by shorting the "TEST" pins together for 5 seconds. Defrost will terminate normally during the "TEST" mode.

Heat Pump Safety Switch Operation

If the unit is equipped with the field installed upgrade safety package, the refrigeration system will be protected against high or low refrigerant pressure and low indoor coil temperature. If any of these three safety switches opens, the unit will be shut off for the 5 minute anti-short cycle time. Once this has expired, a six hour elapsed run timer begins. If a second opening of a safety switch occurs during this six hour period, the compressor will be locked out.

Resetting the lockout function is accomplished by;

1. Removing power from the control's thermostat 1st stage (Y) input for a time not to exceed 5 seconds (ON-OFF-ON).
2. Removing power from "R" for more than 2 seconds.
3. Shorting the "TEST" pins together for more than 2 seconds.

Electric Heat Limit Switch Operation

The limit switch responds to over temperature conditions in the air duct. Opening of the device results in dropping power to the relays. The control logic will also respond by turning off the relays. After four limit cycle trips the unit goes into a 1 hour soft lockout period. If during this period the control "sees" another limit cycle, the unit will go into a hard lockout condition. Once in a hard lockout state, the fan is locked on and the heaters are disabled. **Only a power cycle will clear the state.**

During the soft lockout period, the fan responds to thermostat input but the heaters are enabled. This is to sense a failed heater relay. The limit cycle count is reset at the start of a heat request. If the limit remains open for period of 80 seconds or more, the control is immediately put into a hard lockout condition. **Only a power cycle will clear this state.**

SECURE OWNER'S APPROVAL: *When the system is functioning properly, secure the owner's approval. Show him the location of all disconnect switches and the thermostat. Teach him how to start and stop the unit and how to adjust temperature settings within the limitations of the system.*

TABLE 21 - THERMOSTAT SIGNALS (SINGLE PHASE UNITS)

SIGNAL	STATE	BOARD FUNCTION
"G"	ON	FAN INSTANT ON
	OFF	FAN INSTANT OFF
"G" & "Y" & "O"	ON	FAN INSTANT ON COMPRESSOR AND OUTDOOR FAN INSTANT ON (AFTER ANTI-SHORT CYCLE DELAY) REVERSING VALVE ENERGIZED SYSTEM OPERATES IN COOLING
	OFF	COMPRESSOR AND OUTDOOR FAN INSTANT OFF FAN 60 SEC. DELAY OFF
"G" & "Y"	ON	FAN INSTANT ON COMPRESSOR AND OUTDOOR FAN INSTANT ON (AFTER ANTI-SHORT CYCLE DELAY) SYSTEM OPERATES IN HEATING
	OFF	COMPRESSOR AND OUTDOOR FAN INSTANT OFF FAN 60 SEC. DELAY OFF
"G" & "W"	ON	FAN INSTANT ON HEATER BANK 1 ELEC. HEAT INSTANT ON HEATER BANK 2 ELEC. HEAT 10 SEC. DELAY ON HEATER BANK 3 ELEC. HEAT 20 SEC. DELAY ON
	OFF	HEATER BANK 3 ELEC. HEAT INSTANT OFF HEATER BANK 2 ELEC. HEAT 1/2 SEC. DELAY OFF HEATER BANK 1 ELEC. HEAT 1 SEC. DELAY OFF FAN 10 SEC. DELAY OFF
"G" & "Y" & "W"	ON	FAN INSTANT ON COMPRESSOR AND OUTDOOR FAN INSTANT ON SYSTEM OPERATES IN HEATING HEATER BANK 1 ELEC. HEAT INSTANT ON HEATER BANK 2 ELEC. HEAT 10 SEC. DELAY ON HEATER BANK 3 ELEC. HEAT 20 SEC. DELAY ON
	OFF	COMPRESSOR AND OUTDOOR FAN INSTANT OFF HEATER BANK 3 ELEC. HEAT INSTANT OFF HEATER BANK 2 ELEC. HEAT 1/2 SEC. DELAY OFF HEATER BANK 1 ELEC. HEAT 1 SEC. DELAY OFF FAN 60 SEC. DELAY OFF
"W"	ON	FAN INSTANT ON HEATER BANK 1 ELEC. HEAT INSTANT ON HEATER BANK 2 ELEC. HEAT 10 SEC. DELAY ON HEATER BANK 3 ELEC. HEAT 20 SEC. DELAY ON
	OFF	HEATER BANK 3 ELEC. HEAT INSTANT OFF HEATER BANK 2 ELEC. HEAT 1/2 SEC. DELAY OFF HEATER BANK 1 ELEC. HEAT 1 SEC. DELAY OFF FAN 10 SEC. DELAY OFF

TABLE 22 - THERMOSTAT SIGNALS (THREE PHASE UNITS)

SIGNAL	STATE	BOARD FUNCTION
"G"	ON	FAN INSTANT ON
	OFF	FAN INSTANT OFF
"G" & "Y" & "O"	ON	FAN INSTANT ON COMPRESSOR AND OUTDOOR FAN INSTANT ON (AFTER ANTI-SHORT CYCLE DELAY) REVERSING VALVE ENERGIZED SYSTEM OPERATES IN COOLING
	OFF	COMPRESSOR AND OUTDOOR FAN INSTANT OFF FAN 60 SEC. DELAY OFF
"G" & "Y"	ON	FAN INSTANT ON COMPRESSOR AND OUTDOOR FAN INSTANT ON (AFTER ANTI-SHORT CYCLE DELAY) SYSTEM OPERATES IN HEATING
	OFF	COMPRESSOR AND OUTDOOR FAN INSTANT OFF FAN 60 SEC. DELAY OFF
"G" & "W"	ON	FAN INSTANT ON HEATER BANK 1, 2 & 3 ELEC. HEAT INSTANT ON HEATER BANK 4, 5 & 6 ELEC. HEAT 10 SEC. DELAY ON
	OFF	HEATER BANK 4, 5 & 6 ELEC. HEAT INSTANT OFF HEATER BANK 1, 2 & 3 ELEC. HEAT 1/2 SEC. DELAY OFF FAN 10 SEC. DELAY OFF
"G" & "Y" & "W"	ON	FAN INSTANT ON COMPRESSOR AND OUTDOOR FAN INSTANT ON SYSTEM OPERATES IN HEATING HEATER BANK 1, 2 & 3 ELEC. HEAT INSTANT ON HEATER BANK 4, 5 & 6 ELEC. HEAT 10 SEC. DELAY ON
	OFF	COMPRESSOR AND OUTDOOR FAN INSTANT OFF HEATER BANK 4, 5 & 6 ELEC. HEAT INSTANT OFF HEATER BANK 1, 2 & 3 ELEC. HEAT 1/2 SEC. DELAY OFF FAN 60 SEC. DELAY OFF
"W"	ON	FAN INSTANT ON HEATER BANK 1, 2 & 3 ELEC. HEAT INSTANT ON HEATER BANK 4, 5 & 6 ELEC. HEAT 10 SEC. DELAY ON
	OFF	HEATER BANK 4, 5 & 6 ELEC. HEAT INSTANT OFF HEATER BANK 1, 2 & 3 ELEC. HEAT 1/2 SEC. DELAY OFF FAN 10 SEC. DELAY OFF

MAINTENANCE

NORMAL MAINTENANCE

WARNING: Prior to any of the following maintenance procedures, shut off all power to the unit, to avoid personal injury.

Periodic maintenance consists of changing or cleaning filters and general cleaning of the outdoor coil.

FILTERS - Inspect once a month. Replace Disposable or clean Permanent Type as necessary. DO NOT replace Permanent Type with Disposable.

MOTORS - Indoor and outdoor fan motors are permanently lubricated and require no maintenance.

OUTDOOR COIL - Dirt should not be allowed to accumulate on the outdoor coil surface or other parts in the air circuit. Cleaning should be as often as necessary to keep the coil clean. Use a brush, vacuum cleaner attachment, or other suitable means. If water is used to clean the coil, be sure that the power to the unit is shut off prior to cleaning.

CAUTION: Exercise care when cleaning the coil so that the coil fins are not damaged.

Do not permit the hot condenser air discharge to be obstructed by overhanging structures or shrubs.

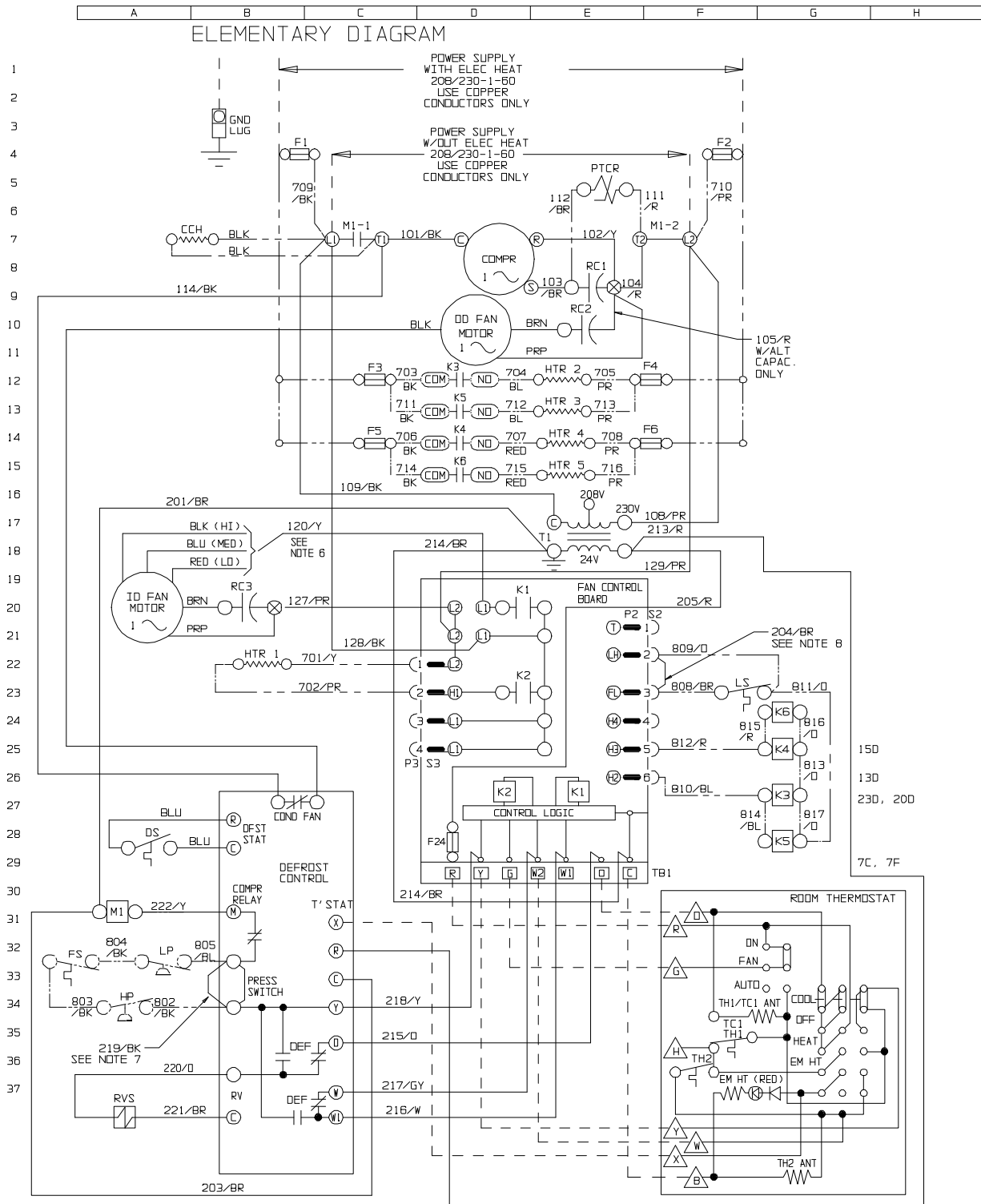

FIG. 4 - TYPICAL WIRING DIAGRAM (208/230-1-60 POWER SUPPLY)

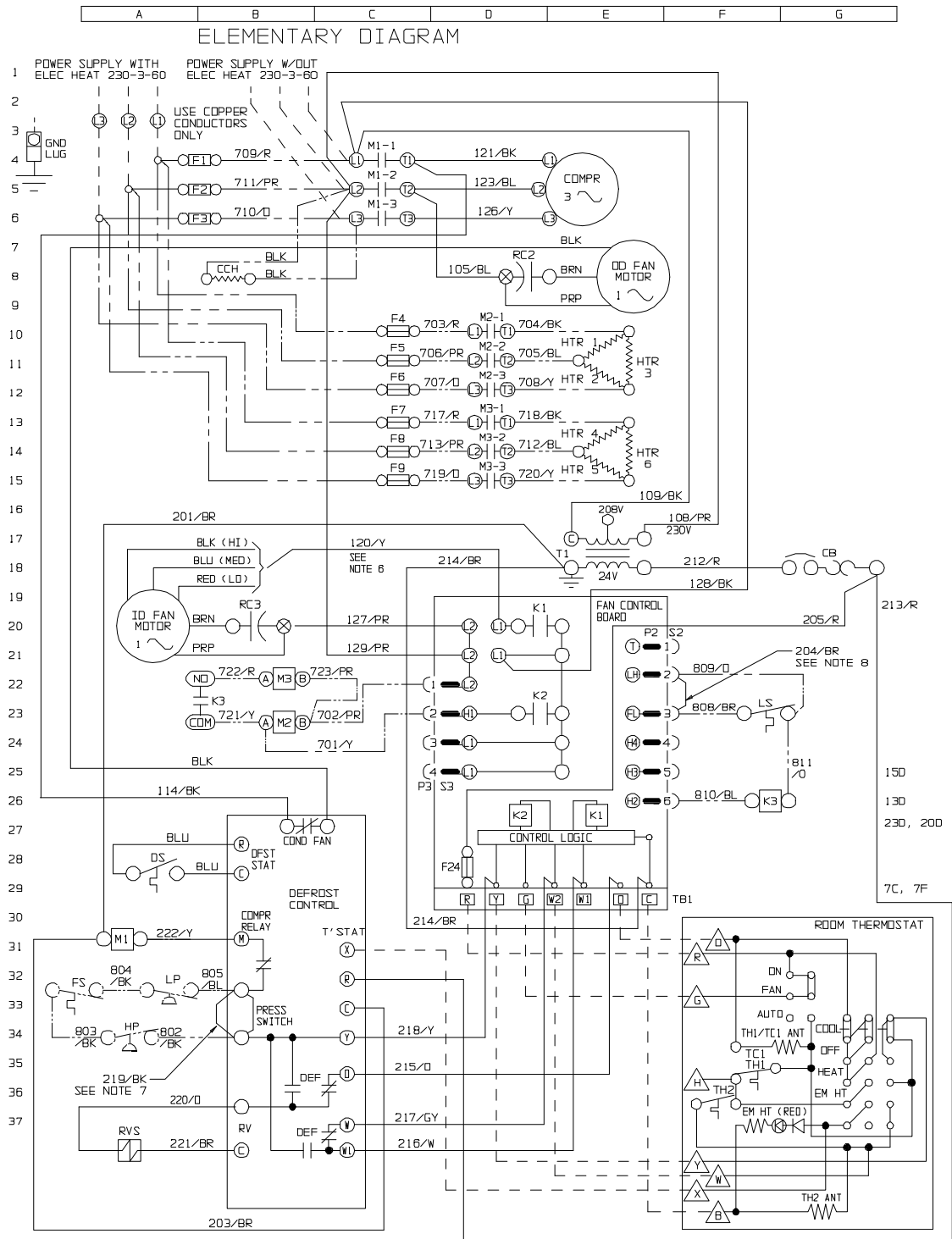

FIG. 5 - TYPICAL WIRING DIAGRAM (230-3-60 POWER SUPPLY)

TYPICAL WIRING DIAGRAM LEGEND (See page 15, 16 and 17)

CB	CIRCUIT BREAKER, 3 AMP
CCH	CRANKCASE HEATER
COMPR	COMPRESSOR
DS	DEFROST SENSOR, CLOSES @ 31°F, OPENS @ 55°F.
F1, F2	FUSES, LINE VOLTAGE - 60 AMP (5, 7.5, 10, & 15 KW ELEC HEAT)
F3, F4	FUSES, LINE VOLTAGE - 30 AMP (7.5, 10, & 15 KW ELEC HEAT)
F5, F6	FUSES, LINE VOLTAGE - 30 AMP (15 KW ELEC HEAT)
F24	FUSE 24V SECONDARY, 5 AMP
FS	FREEZESTAT SWITCH (OPTIONAL ACCESSORY) OPEN @ 26°F
HP	HIGH PRESSURE SWITCH (OPTIONAL ACCESSORY) OPENS @ 380 PSIG
HTR 1	ELECTRIC HEATER (OPT. ACCESSRY: 5, 7.5, 10, & 15 KW ELEC HEAT)
HTR 2	ELECTRIC HEATER (OPT. ACCESSRY: 7.5, 10, & 15 KW ELEC HEAT)
HTR 3	ELECTRIC HEATER (OPT. ACCESSRY: 15 KW ELEC HEAT)
K1	RELAY INDOOR FAN MOTOR
K2	RELAY ELECTRIC HEATER
K3	RELAY ELECTRIC HEATER, 24 VDC COIL (7.5, 10, & 15 KW ELEC HEAT)
K4	RELAY ELECTRIC HEATER, 24 VDC COIL (15 KW ELEC HEAT)
LP	LOW PRESSURE SWITCH (OPTIONAL ACCESSORY) OPEN @ 7 PSIG
LS	LIMIT SWITCH, ELECTRIC HEAT (PART OF ELEC HEAT ACCESSORY)
M1	CONTACTOR, COMPRESSOR & OUTDOOR FAN
M2	CONTACTOR, INDOOR BLOWER MOTOR
M3	CONTACTOR, OUTDOOR FAN MOTOR
RC1/RC2	COMPRESSOR & OUTDOOR FAN RUN CAPACITOR
RC1	COMPRESSOR RUN CAPACITOR (ALTERNATE)
RC2	OUTDOOR FAN RUN CAPACITOR (ALTERNATE)
RC3	INDOOR FAN RUN CAPACITOR
RVS	REVERSING VALVE SOLENOID
S2/P2	SOCKET/PLUG CONNECTION ON FAN CONTROL BOARD, LOW VOLTAGE
S3/P3	SOCKET/PLUG CONNECTION ON FAN CONTROL BOARD, LINE VOLTAGE
T1	TRANSFORMER, 24V, 40 VA
⊗	IDENTIFIED TERMINAL ON RUN CAPACITOR
Δ	ROOM THERMOSTAT 24V CONNECTIONS
□	TB1 ON FAN/ELEC HEAT CONTROL BOARD
—————	FACTORY WIRING AND DEVICES
-----	OPTIONAL WIRING AND DEVICES
- - - - -	FIELD WIRING

TYPICAL WIRING DIAGRAM NOTES (See page 15, 16 and 17)

1. ALL FIELD WIRING TO BE ACCOMPLISHED FOLLOWING CITY, LOCAL AND/OR NATIONAL CODES IN EFFECT AT TIME OF INSTALLATION OF THIS UNIT.
2. CAUTION: LABEL ALL WIRES PRIOR TO DISCONNECTION WHEN SERVICING CONTROLS. WIRING ERRORS CAN CAUSE IMPROPER AND DANGEROUS OPERATION. IF ANY OF THE WIRE AS SUPPLIED WITH THIS UNIT MUST BE REMOVED, IT MUST BE REPLACED WITH TYPE 105° C, 600V WIRE OR EQUIVALENT CLEARLY RENUMBERED FOR IDENTIFICATION. VERIFY PROPER OPERATION AFTER SERVICING.
3. MOTORS ARE INHERENTLY PROTECTED.
4. UNIT FACTORY WIRED FOR 230 VOLT OPERATION. FOR 208 VOLT OPERATION MOVE '108/PR' WIRE FROM 240V TO 208V ON TRANSFORMER T1.
5. SEE UNIT NAMEPLATE FOR MAXIMUM FUSE SIZE AND MINIMUM CIRCUIT AMPACITY.
6. SELECT INDOOR BLOWER SPEED TO OBTAIN APPROX 400 CFM/TON IN COOLING.
7. IF OPTIONAL SAFETY SWITCH KIT IS INSTALLED, WIRE 219/BK IS REMOVED.
8. WIRE 204/BR IS REMOVED WHEN ELECTRIC HEAT IS INSTALLED.

CAUTION - OPEN ALL DISCONNECTS
BEFORE SERVICING THIS UNIT



 **YORK**[®]

Heating and Air Conditioning

Unitary Products Group
5005 York Drive, Norman, Oklahoma 73069
Subject to change without notice. Printed in U.S.A.
Copyright © by York International Corporation 2000. All Rights Reserved



Proud Sponsor
of the 2000
U.S. Olympic Team