

JOB NAME \_\_\_\_\_ LOCATION \_\_\_\_\_  
PURCHASER \_\_\_\_\_ ORDER NO. \_\_\_\_\_  
ENGINEER \_\_\_\_\_  
SUBMITTED TO \_\_\_\_\_ FOR: Reference Approval Construction  
SUBMITTED BY \_\_\_\_\_ DATE \_\_\_\_\_

UNIT DESIGNATION: Schedule No. \_\_\_\_\_ MODEL NO. \_\_\_\_\_

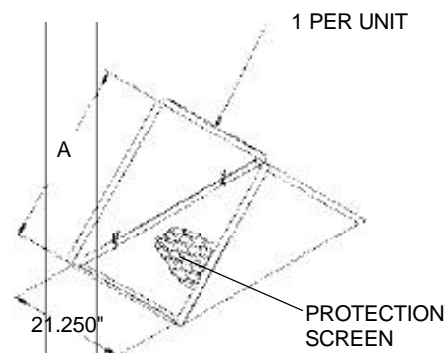
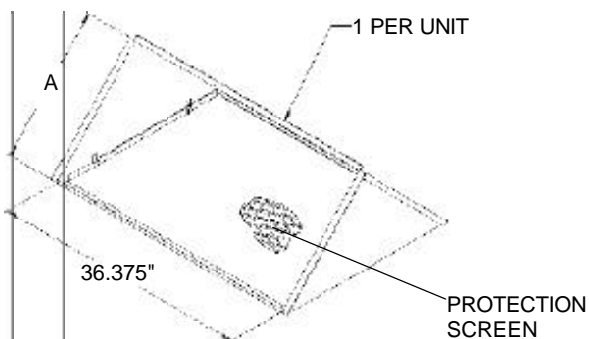
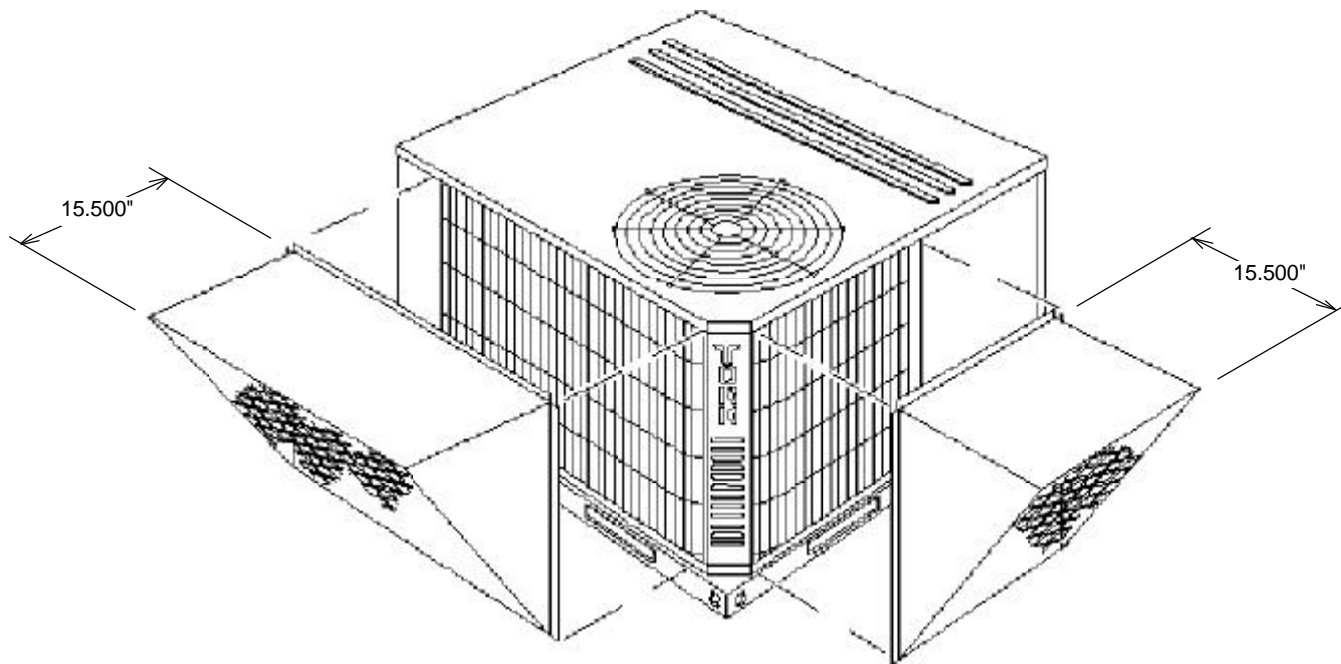

MODEL	DIMENSION "A"	UNIT SIZE
1HG0814	29.125"	1½ THRU 3½ TON (10 SEER), 1½ THRU 3 TON (12 SEER)
1HG0818	37.125"	4 AND 5 TON (10 SEER), 3½ THRU 5 TON (12 SEER)

**NOTE:**

The Hail Guard is made of 18 gauge expanded steel with the hoods painted to match the unit. Two (2) hoods, one each, are supplied in this kit. Mounting hardware is field provided.

Sub ject to change with out no tice. Printed in the U. S. A.

**HAIL GUARD KIT**  
**MODELS: 1HG0814 AND 1HG0818**  
**(FOR COOLING AND HEAT PUMP UNITS)**

FORM 530.46-SD17Y-0502

Supersedes: 530.46-SD17Y (597)

